

**Centre Scientifique et  
Technique du Bâtiment**

84 avenue Jean Jaurès  
CHAMPS-SUR-MARNE  
F-77447 Marne-la-Vallée Cedex 2

Tél. : (33) 01 64 68 82 82

Fax : (33) 01 60 05 70 37

**European Technical  
Assessment**

**ETA-18/0663  
of 23/08/2018**

*English translation prepared by CSTB - Original version in French language*

**General Part**

Nom commercial:  
*Trade name*

**Injection system ARVEX CV**

Famille de produit :  
*Product family*

**Cheville à scellement de type "à injection" pour fixation dans le béton : M8 à M24, fers à béton 8 à 25mm**  
***Bonded injection type anchor for use in concrete: sizes M8 to M24, rebar 8 to 25mm***

Titulaire:  
*Manufacturer*

ARVEX GROBELNY Sp. z o.o.  
30-969 Kraków, ul. Makuszyńskiego 4  
Poland

Usine de fabrication:  
*Manufacturing plant*

ARVEX Plant 1

Cette évaluation contient:  
*This assessment contains*

22 pages incluant 19 pages d'annexes qui font partie intégrante de cette évaluation  
*22 pages including 19 pages of annexes which form an integral part of this assessment*

Base de l'ETE:  
*Basis of ETA*

DEE 15-33-0499-06.01  
EAD 15-33-0499-06.01

Cette Evaluation remplace :  
*This Assessment replaces*

-  
-

## Specific part

### 1 Technical description of the product

The injection system ARVEX CV is a bonded anchor (injection type) consisting of a mortar cartridge with ARVEX resin ARVEX CV and a steel element. The steel elements are threaded rods made of zinc coated steel, stainless steel, high corrosion resistant stainless steel (HCR), or rebar.

The steel element is placed into a drilled hole filled with injection mortar and is anchored via the bond between steel element, injection mortar and concrete. The steel element is intended to be used with embedment depth from 4 diameters to 20 diameters.

The illustration and the description of the product are given in Annexes A.

### 2 Specification of the intended use

The performances given in Section 3 are only valid if the anchor is used in compliance with the specifications and conditions given in Annexes B.

The provisions made in this European Technical Assessment are based on an assumed working life of the anchor of 50 years. The indications given on the working life cannot be interpreted as a guarantee given by the producer, but are to be regarded only as a means for choosing the right products in relation to the expected economically reasonable working life of the works.

### 3 Performance of the product

#### 3.1 Mechanical resistance and stability (BWR 1)

Essential characteristic	Performance
Characteristic resistance under tension loads for threaded rod Acc. TR029	See Annex C1
Characteristic resistance under tension loads for rebars Acc. TR029	See Annex C2
Characteristic resistance under shear loads for threaded rods Acc. TR029	See Annex C3
Characteristic resistance under shear loads for rebars Acc. TR029	See Annex C4
Characteristic resistance under tension loads for threaded rods Acc. CEN/TS	See Annex C5
Characteristic resistance under tension loads for rebars Acc. CEN/TS	See Annex C6
Characteristic resistance under shear loads for threaded rods Acc. CEN/TS	See Annex C7
Characteristic resistance under shear loads for rebars Acc. CEN/TS	See Annex C8
Displacement for threaded rods and rebars	See Annex C9

#### 3.2 Safety in case of fire (BWR 2)

Essential characteristic	Performance
Reaction to fire	Anchorage satisfy requirements for Class A1
Resistance to fire	No performance determined (NPD)

#### 3.3 Hygiene, health and the environment (BWR 3)

Regarding dangerous substances contained in this European Technical Assessment, there may be requirements applicable to the products falling within its scope (e.g. transposed European legislation and national laws, regulations and administrative provisions). In order to meet the provisions of the Construction Products Directive, these requirements need also to be complied with, when and where they apply.

**3.4 Safety in use (BWR 4)**

For Basic Requirement Safety in use the same criteria are valid as for Basic Requirement Mechanical resistance and stability.

**3.5 Protection against noise (BWR 5)**

Not relevant.

**3.6 Energy economy and heat retention (BWR 6)**

Not relevant.

**3.7 General aspects relating to fitness for use**

Durability and Serviceability are only ensured if the specifications of intended use according to Annex B1 are kept.

**4 Assessment and verification of constancy of performance (AVCP)**

According to the Decision 96/582/EC of the European Commission<sup>1</sup>, as amended, the system of assessment and verification of constancy of performance (see Annex V to Regulation (EU) No 305/2011) given in the following table apply.

Product	Intended use	Level or class	System
Metal anchors for use in concrete	For fixing and/or supporting to concrete, structural elements (which contributes to the stability of the works) or heavy units	—	1

**5 Technical details necessary for the implementation of the AVCP system**

Technical details necessary for the implementation of the Assessment and verification of constancy of performance (AVCP) system are laid down in the control plan deposited at Centre Scientifique et Technique du Bâtiment.

The manufacturer shall, on the basis of a contract, involve a notified body approved in the field of anchors for issuing the certificate of conformity CE based on the control plan.

**The original French version is signed by**

Charles Baloche  
Technical Director

<sup>1</sup> Official Journal of the European Communities L 254 of 08.10.1996

**Threaded rod M8, M10, M12, M16, M20, M24**

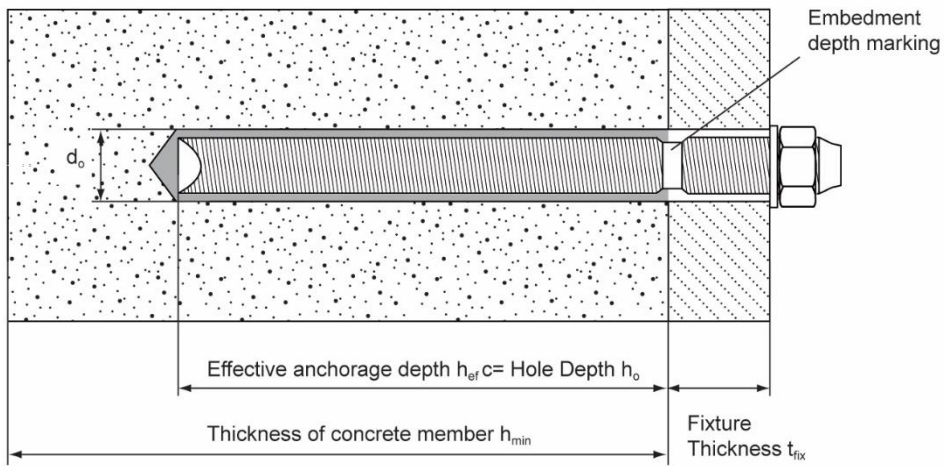

**Reinforcing bar Ø8, Ø10, Ø12, Ø14, Ø16, Ø20, Ø25 acc. to Annex 4**

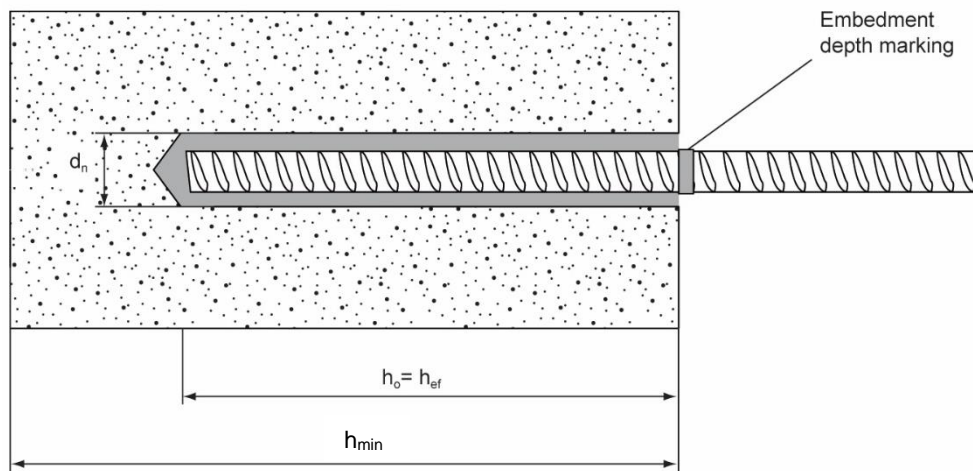

ARVEX CV

Product description  
 Installation condition

Annex A1

### ARVEX Chemical anchoring system: ARVEX CV

Foil Bag Cartridge 150ml - 410ml

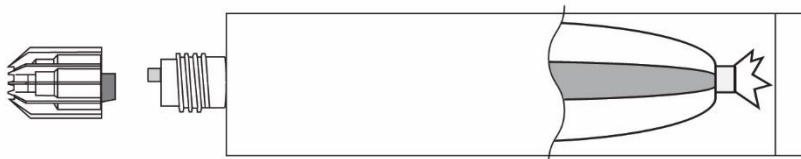

Coaxial Cartridge  
380ml - 410ml

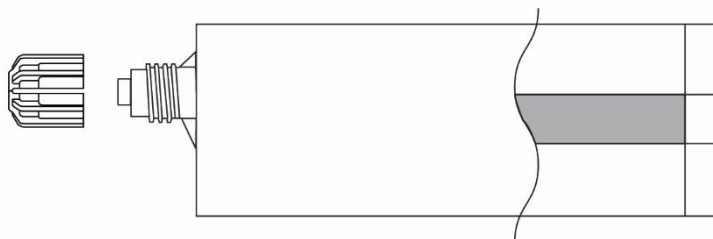

Side by Side Cartridge  
235ml - 825ml

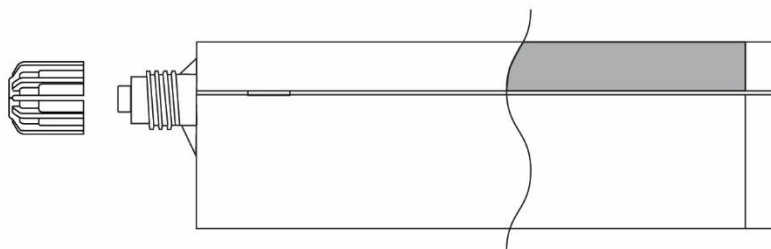

#### Marking:

ARVEX CV

Batch code, either expiry date or manufacturing date with shelf life

#### Mixer with hanger

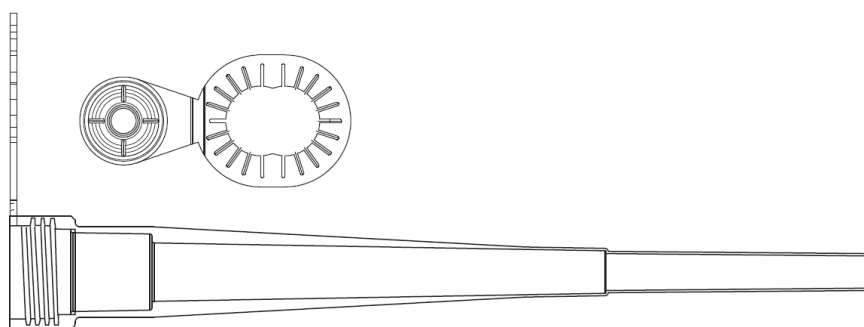

ARVEX CV

Product description

Injection system

Annex A2

**Anchor rod and rebar:**

**Threaded Steel Stud, Nut and Washer**  
 Sizes M8, M10, M12, M16, M20, M24.

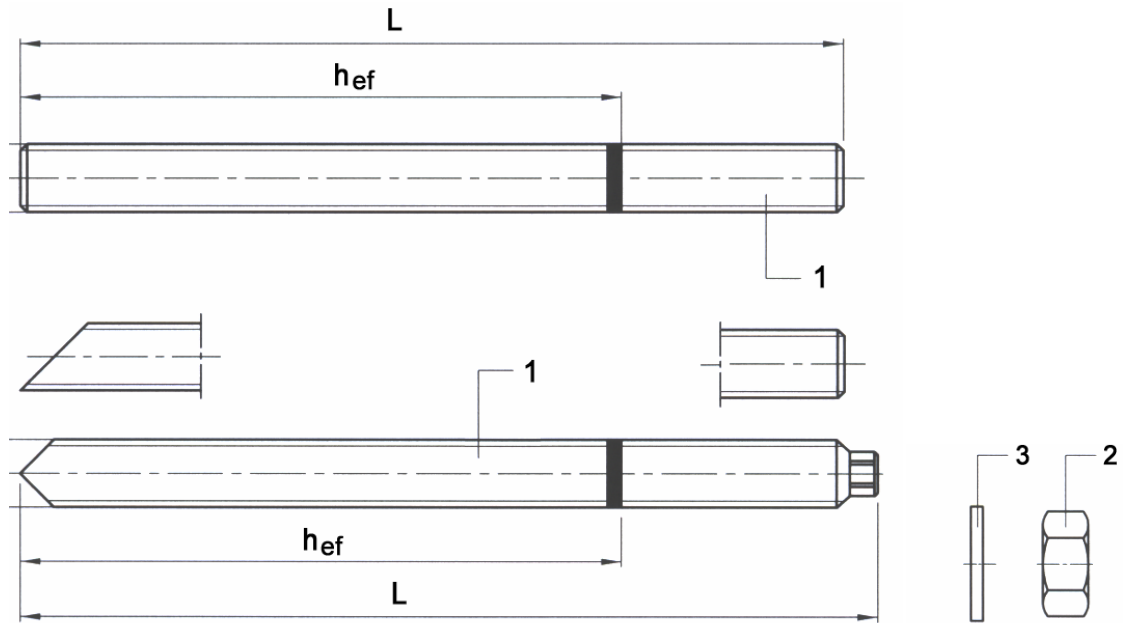

Commercial standard rod with:

- Materials, dimensions and mechanical properties (Table 1a)
- Inspection certificate 3.1 acc. to EN 10204:2004
- Marking of embedment depth

**Rebar**

Diameter  $\varnothing$  8mm,  $\varnothing$  10mm,  $\varnothing$  12mm,  $\varnothing$  14mm,  $\varnothing$  16mm,  $\varnothing$  20mm,  $\varnothing$  25mm



**ARVEX CV**

**Product description**

Threaded rods and rebars

**Annex A3**

**Table A1: Materials**

Designation	Material
<b>Threaded rods made of zinc coated steel</b>	
Threaded rod M8 – M24	Strength class 5.8, 8.8, 10.9 EN ISO 898-1, Steel galvanized $\geq 5\mu\text{m}$ EN ISO 4042, Hot dipped galvanized $\geq 45\mu\text{m}$ EN ISO 10684
Washer ISO 7089	Steel galvanized EN ISO 4042; hot dipped galvanized EN ISO 10684
Nut EN ISO 4032	Strength class 8 EN ISO 898-2 Steel galvanized $\geq 5\mu\text{m}$ EN ISO 4042 Hot dipped galvanized $\geq 45\mu\text{m}$ EN ISO 10684
<b>Threaded rods made of stainless steel</b>	
Threaded rod M8 – M24	For $\leq$ M24: strength class 70 EN ISO 3506-1; Stainless steel 1.4401; 1.4404; 1.4578; 1.4571; 1.4439; 1.4362 EN 10088
Washer ISO 7089	Stainless steel 1.4401; 1.4404; 1.4578; 1.4571; 1.4439; 1.4362 EN 10088
Nut EN ISO 4032	Strength class 70 EN ISO 3506-2 Stainless steel 1.4401; 1.4404; 1.4578; 1.4571; 1.4439; 1.4362 EN 10088
<b>Threaded rods made of high corrosion resistant steel</b>	
Threaded rod M8 – M24	For $\leq$ M20: $R_m = 800\text{ N/mm}^2$ ; $R_{p0,2} = 640\text{ N/mm}^2$ , For $>$ M20: $R_m = 700\text{ N/mm}^2$ ; $R_{p0,2} = 400\text{ N/mm}^2$ , High corrosion resistant steel 1.4529, 1.4565 EN 10088
Washer ISO 7089	High corrosion resistant steel 1.4529, 1.4565 EN 10088
Nut EN ISO 4032	Strength class 70 EN ISO 3506-2 High corrosion resistant steel 1.4529, 1.4565 EN 10088

**Table A2: Properties of reinforcement bars (rebars)**

Product form	Bars and de-coiled rods	
Class	B	C
Characteristic yield strength $f_{yk}$ or $f_{0,2k}$ (MPa)	400 to 600	
Minimum value of $k = (f_t / f_y)k$	$\geq 1,08$	$\geq 1,15$ $< 1,35$
Characteristic strain at maximum force, $\epsilon_{uk}$ (%)	$\geq 5,0$	$\geq 7,5$
Bendability	Bend / Rebend test	
Maximum deviation from nominal mass (individual bar) (%)	Nominal bar size (mm) $\leq 8$	$\pm 6,0$
	$> 8$	$\pm 4,5$
Bond: Minimum relative rib area, $f_{R,min}$ (determination according to EN 15630)	Nominal bar size (mm) 8 to 12	0,040
	$> 12$	0,056

**Height of the rebar rib  $h_{rib}$ :**

The height of the rebar rib  $h_{rib}$  shall fulfil the following requirement:  $0,05 * d \leq h_{rib} \leq 0,07 * d$   
 with:  $d$  = nominal diameter of the rebar

**ARVEX CV**

**Product description**

Threaded rods and rebars

**Annex A4**

## Specifications of intended use

### Anchorage subject to:

- Static and quasi-static loads

### Base materials:

- Cracked concrete and non-cracked concrete
- Reinforced or unreinforced normal weight concrete of strength classes C 20/25 at least to C50/60 at most according to EN 206: 2000-12.

### Temperature Range:

- Ta: - 40°C to +40°C (max. short term temperature +40°C and max. long term temperature +24°C)
- Tb: - 40°C to +80°C (max. short term temperature +80°C and max. long term temperature +50°C)

### Use conditions (Environmental conditions):

- Structures subject to dry internal conditions (zinc coated steel, stainless steel, high corrosion resistance steel).
- Structures subject to permanently damp internal condition, if no particular aggressive conditions exist (stainless steel, high corrosion resistance steel).
- Structures subject to permanently damp internal condition, with particular aggressive conditions (high corrosion resistance steel).
- Structures subject to external atmospheric exposure including industrial and marine environment if no particular aggressive conditions exist (stainless steel, high corrosion resistance steel).

Note: Particular aggressive conditions are e.g. permanent, alternating immersion in seawater or the splash zone of seawater, chloride atmosphere of indoor swimming pools or atmosphere with extreme chemical pollution (e.g. in desulphurization plants or road tunnels where de-icing materials are used).

### Design:

- The anchorages are designed in accordance with the EOTA Technical Report TR 029 "Design of bonded anchors" and CEN/TS 1992-4-5 "Design of fastenings for use in concrete" under the responsibility of an engineer experienced in anchorages and concrete work
- Verifiable calculation notes and drawings are prepared taking account of the loads to be anchored. The position of the anchor is indicated on the design drawings.

### Installation:

- Dry or wet concrete (category 1).
- Hole drilling by rotary drill mode.
- Overhead installation is not permitted
- Installation in cracked concrete for threaded rods sizes M12 and M16 only
- Anchor installation carried out by appropriately qualified personnel and under the supervision of the person responsible for technical matters of the site.

ARVEX CV

Intended Use  
Specifications

Annex B1



**Table B1: Bore hole cleaning method with Steel brush**

Threaded rod and rebar	Size	Nominal drill bit diameter $d_o$ (mm)	Steel Brush	Cleaning methods	
				Manual cleaning (MAC)	Compressed air cleaning (CAC)
					
<b>Studs</b> 	M8	10	12mm	Yes ... $h_{ef} \leq 80$ mm	Yes
	M10	12	14mm	Yes ... $h_{ef} \leq 100$ mm	
	M12	14	16mm	Yes ... $h_{ef} \leq 120$ mm	
	M16	18	20mm	Yes ... $h_{ef} \leq 160$ mm	
	M20	24	26mm	Yes ... $h_{ef} \leq 200$ mm	
	M24	28	30mm	Yes ... $h_{ef} \leq 240$ mm	
<b>Rebar</b> 	Ø8	12	14mm	Yes ... $h_{ef} \leq 80$ mm	Yes
	Ø10	14	16mm	Yes ... $h_{ef} \leq 100$ mm	
	Ø12	16	18mm	Yes ... $h_{ef} \leq 120$ mm	
	Ø14	18	20mm	Yes ... $h_{ef} \leq 140$ mm	
	Ø16	20	22mm	Yes ... $h_{ef} \leq 160$ mm	
	Ø20	25	28mm	Yes ... $h_{ef} \leq 200$ mm	
	Ø25	32	34mm	Yes ... $h_{ef} \leq 240$ mm	

**Manual Cleaning (MAC):**

ARVEX hand pump recommended for blowing out bore holes with diameters  $d_o \leq 24$  mm and bore holes depth  $h_o \leq 10d$



**Compressed air cleaning (CAC):**

Recommended air nozzle with an opening of minimum 3,5mm in diameter.



ARVEX CV

**Intended Use**

Cleaning brush  
 Applicator guns

**Annex B2**

**Table B2a: Installation parameters: drilling, hole cleaning and installation**

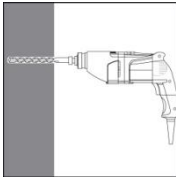
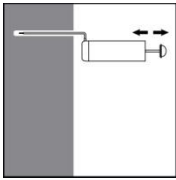
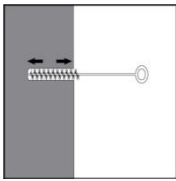
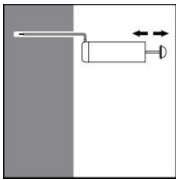
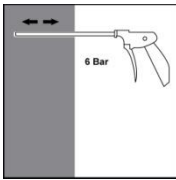
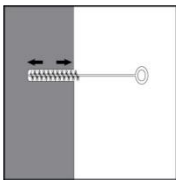
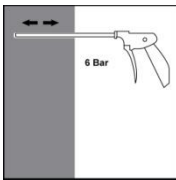
Instructions for use		
Bore hole drilling		
		Drill hole in the substrate to the required embedment depth using the appropriately sized carbide drill bit.
Bore hole cleaning Just before setting an anchor, the bore hole must be free of dust and debris.		
a) Manual air cleaning (MAC) for all bore hole diameters $d_o \leq 24\text{mm}$ and bore hole depth $h_o \leq 10d$		
	X 4	The ARVEX manual pump shall be used for blowing out bore holes up to diameters $d_o \leq 24\text{mm}$ and embedment depths up to $h_{ef} \leq 10d$ .  Blow out at least 4 times from the back of the bore hole, using an extension if needed.
	X 4	Brush 4 times with the specified brush size (see Table B1) by inserting the ARVEX steel brush to the back of the hole (if needed with an extension) in a twisting motion and removing it.
	X 4	Blow out again with manual pump at least 4 times.
b) Compressed air cleaning (CAC) for all bore hole diameters $d_o$ and all bore hole depths		
	X 2	Blow 2 times from the back of the hole (if needed with a nozzle extension) over the whole length with oil-free compressed air (min. 6 bar at $6\text{ m}^3/\text{h}$ ).
	X 2	Brush 2 times with the specified brush size (see Table B1) by inserting the ARVEX steel brush to the back of the hole (if needed with an extension) in a twisting motion and removing it.
	X 2	Blow out again with compressed air at least 2 times.

ARVEX CV

Intended Use

Manufacturer Published Installation Instructions

Annex B3

**Table B2b: Installation parameters: drilling, hole cleaning and installation**

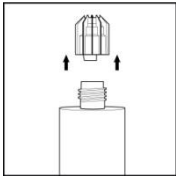
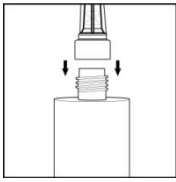
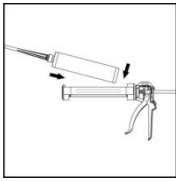
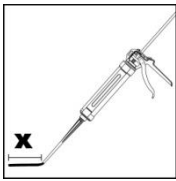
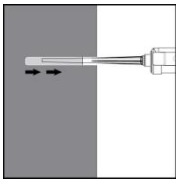
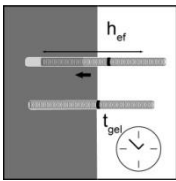
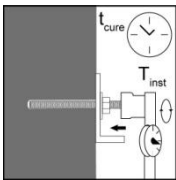
Instructions for use	
	Remove the threaded cap from the cartridge.
	Tightly attach the mixing nozzle. Do not modify the mixer in any way. Make sure the mixing element is inside the mixer. Use only the supplied mixer.
	Insert the cartridge into the ARVEX dispenser gun.
	Discard the initial trigger pulls of adhesive. Depending on the size of the cartridge, an initial amount of adhesive mix must be discarded.  Discard quantities are - 5cm for between 150ml, 300ml & 400ml Foil Pack - 10cm for all other cartridges
	Inject the adhesive starting at the back of the hole, slowly withdrawing the mixer with each trigger pull. Fill holes approximately 2/3 full, to ensure that the annular gap between the anchor and the concrete is completely filled with adhesive along the embedment depth.
	Before use, verify that the threaded rod is dry and free of contaminants.  Install the threaded rod to the required embedment depth during the open gel time $t_{gel}$ has elapsed. The working time $t_{gel}$ is given in Table B3.
	The anchor can be loaded after the required curing time $t_{cure}$ (see Table B3) The applied torque shall not exceed the values $T_{max}$ given in Table B4.

**ARVEX CV**

**Intended Use**

Manufacturer Published Installation Instructions

**Annex B3**

**Table B3: Minimum curing time**

Minimum base material temperature C°	Gel time (working time) $t_{gel}$ In dry/wet concrete	Cure time
0° ≤ $T_{base\ material}$ < 5°C	25 min	90 min
5°C ≤ $T_{base\ material}$ < 10°C	17 min	70 min
10°C ≤ $T_{base\ material}$ < 20°C	12 min	65 min
20°C ≤ $T_{base\ material}$ < 30°C	6 min	60 min
30°C ≤ $T_{base\ material}$ ≤ 40°C	3 min	45 min

The temperature of the bond material must be ≥ 20°C

**ARVEX CV**

**Intended Use**

Gelling and curing times

**Annex B4**

**Table B4: Installation details for anchor rods**

Anchor size			M8	M10	M12	M16	M20	M24
Diameter of anchor rod	d	[mm]	8	10	12	16	20	24
Range of anchorage depth $h_{ef}$ and bore hole depth $h_o$	min	[mm]	60	60	70	80	90	100
	max	[mm]	160	200	240	320	400	480
Nominal anchorage depth	$h_{ef}$	[mm]	80	90	110	125	170	210
Nominal diameter of drill bit	$d_o$	[mm]	10	12	14	18	24	28
Diameter of clearance hole in the fixture	$d_f$	[mm]	9	12	14	18	22	26
Maximum torque moment	$T_{max}$	[Nm]	10	20	30	60	90	140
Minimum thickness of concrete member	$h_{min}$	[mm]	$h_{ef} + 30mm$ $\geq 100mm$			$h_{ef} + 2d_o$		
Minimum spacing	$S_{min}$	[mm]	40	50	60	80	100	120
Minimum edge distance	$C_{min}$	[mm]	40	50	60	80	100	120

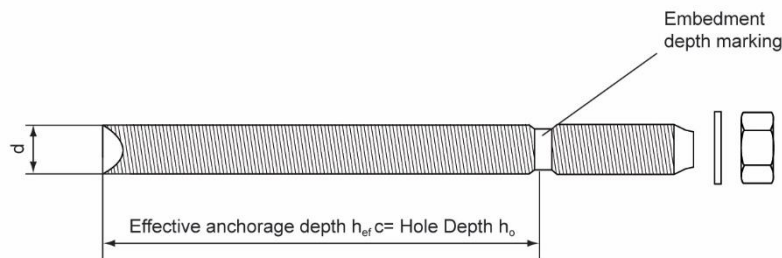

**Table B5 - Installation details for rebars**

Rebar Diameter			Ø8	Ø10	Ø12	Ø14	Ø16	Ø20	Ø25
Diameter of element	D	[mm]	8	10	12	14	16	20	25
Range of anchorage depth $h_{ef}$ and bore hole depth $h_o$	min	[mm]	60	60	70	75	80	90	100
	max	[mm]	160	200	240	280	320	400	500
Nominal diameter of drill bit	$d_o$	[mm]	12	14	16	18	20	25	32
Minimum thickness of concrete member	$h_{min}$	[mm]	$h_{ef} + 30mm$ $\geq 100mm$			$h_{ef} + 2d_o$			
Minimum spacing	$S_{min}$	[mm]	40	50	60	70	80	100	125
Minimum edge distance	$C_{min}$	[mm]	40	50	60	70	80	100	125

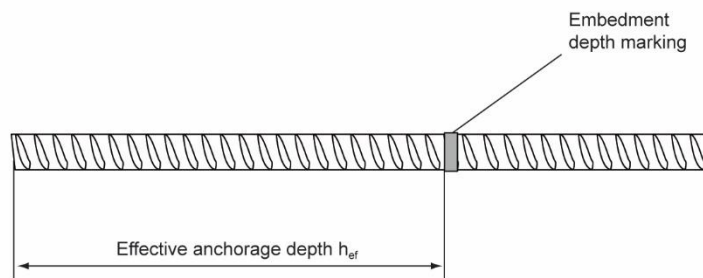

ARVEX CV

Intended Use

Installation parameters

Annex B5

ARVEX CV with threaded rods			M8	M10	M12	M16	M20	M24
<b>Steel failure</b>								
Characteristic resistance, class 5.8	$N_{Rk,s}$	[kN]	18	29	42	79	123	177
Characteristic resistance, class 8.8	$N_{Rk,s}$	[kN]	29	46	67	126	196	282
Partial safety factor	$\gamma_{Ms,N}^{1)}$	[-]	1,5					
Characteristic resistance, class 10.9	$N_{Rk,s}$	[kN]	36	58	84	157	245	353
Partial safety factor	$\gamma_{Ms,N}^{1)}$	[-]	1.4					
Characteristic resistance, A4-70	$N_{Rk,s}$	[kN]	26	41	59	110	172	247
Partial safety factor	$\gamma_{Ms,N}^{1)}$	[-]	1,87					
Characteristic resistance, HCR	$N_{Rk,s}$	[kN]	29	46	67	126	196	247
Partial safety factor	$\gamma_{Ms,N}^{1)}$	[-]	1,5					
<b>Combined Pull-out and Concrete cone failure</b>								
Diameter of threaded rod	d	[mm]	8	10	12	16	20	24
Characteristic bond resistance in non-cracked concrete C20/25								
Temperature range I <sup>2)</sup> : 40°C/24°C	$\tau_{Rk}$	[N/mm <sup>2</sup> ]	10.0	9.5	9.0	8.0	7.5	7.0
Temperature range II <sup>2)</sup> : 80°C/50°C	$\tau_{Rk}$	[N/mm <sup>2</sup> ]	9.0	8.0	7.5	7.0	6.5	6.0
Increasing factor for $\tau_{Rk,p}$ in non-cracked concrete	$\psi_c$	C30/37	1,12					
		C40/50	1,23					
		C50/60	1,30					
Characteristic bond resistance in cracked concrete C20/25								
Temperature range I <sup>2)</sup> : 40°C/24°C	$\tau_{Rk}$	[N/mm <sup>2</sup> ]	- <sup>5)</sup>	- <sup>5)</sup>	3.5	3.5	- <sup>5)</sup>	- <sup>5)</sup>
Temperature range II <sup>2)</sup> : 80°C/50°C	$\tau_{Rk}$	[N/mm <sup>2</sup> ]	- <sup>5)</sup>	- <sup>5)</sup>	3.0	3.0	- <sup>5)</sup>	- <sup>5)</sup>
Increasing factor for $\tau_{Rk,p}$ in cracked concrete	$\psi_c$	C30/37	1,04					
		C40/50	1,07					
		C50/60	1,09					
<b>Splitting failure<sup>2)</sup></b>								
Edge distance $c_{cr,sp}$ [mm] for	$h / h_{ef}^{3)} \geq 2,0$		1,0 $h_{ef}$					
	$2,0 > h / h_{ef}^{3)} > 1,3$		4,6 $h_{ef}$ - 1,8 h					
	$h / h_{ef}^{3)} \leq 1,3$		2,26 $h_{ef}$					
Spacing	$s_{cr,sp}$	[mm]	2 $c_{cr,sp}$					
Partial safety factor	$\gamma_{Mp} = \gamma_{Mc} = \gamma_{Msp}^{1)}$	[-]	1,5 <sup>4)</sup>	1,5 <sup>4)</sup>	1,5 <sup>4)</sup>	1,5 <sup>4)</sup>	1,5 <sup>4)</sup>	1,5 <sup>4)</sup>

- 1) In absence of national regulations
- 2) Explanations, see Annex B1
- 3) h concrete member thickness,  $h_{ef}$  effective anchorage depth
- 4) The partial safety factor  $\gamma_2 = 1,0$  is included
- 5) Not qualified in cracked concrete

<b>ARVEX CV</b>	<b>Annex C1</b>
<b>Design according to TR 029</b>	
Characteristic resistance under tension loads for threaded rods	

ARVEX CV with rebar			Ø8	Ø10	Ø12	Ø14	Ø16	Ø20	Ø25
<b>Steel failure rebar</b>									
Characteristic resistance for rebar BSt 500 S acc. to DIN 488 <sup>1)</sup>	$N_{Rk,s}$	[kN]	28	43	62	85	111	173	270
Partial safety factor for rebar BSt 500 S acc. to DIN 488 <sup>2)</sup>	$\gamma_{Ms,N}$ <sup>3)</sup>	[-]	1,4						
<b>Combined Pull-out and Concrete cone failure</b>									
Diameter of rebar	d	[mm]	8	10	12	14	16	20	25
Characteristic bond resistance in non-cracked concrete C20/25									
Temperature range I <sup>4)</sup> : 40°C/24°C	$\tau_{Rk}$	[N/mm <sup>2</sup> ]	7,0	7,5	7,0	7,0	6,5	6,5	6,0
Temperature range II <sup>4)</sup> : 80°C/50°C	$\tau_{Rk}$	[N/mm <sup>2</sup> ]	6.5	6.5	6,0	6,0	6,0	5,5	5,5
Increasing factor for $\tau_{Rk,p}$ in non-cracked concrete	$\psi_c$	C30/37	1,12						
		C40/50	1,23						
		C50/60	1,30						
<b>Splitting failure</b>									
Edge distance $c_{cr,sp}$ [mm] for	$h / h_{ef}^{5)} \geq 2,0$		<b>1,0 <math>h_{ef}</math></b>						
	$2,0 > h / h_{ef}^{5)} > 1,3$		<b>4,6 <math>h_{ef}</math> - 1,8 h</b>						
	$h / h_{ef}^{5)} \leq 1,3$		<b>2,26 <math>h_{ef}</math></b>						
Spacing	$s_{cr,sp}$	[mm]	<b>2 <math>c_{cr,sp}</math></b>						
Partial safety factor	$\gamma_{Mp} = \gamma_{Mc} = \gamma_{Msp}$ <sup>3)</sup>	[-]	1,8 <sup>6)</sup>	1,8 <sup>6)</sup>	1,8 <sup>6)</sup>	1,8 <sup>6)</sup>	1,8 <sup>6)</sup>	1,8 <sup>6)</sup>	1,8 <sup>6)</sup>
<ol style="list-style-type: none"> <li>1) The characteristic tension resistance <math>N_{Rk,s}</math> for rebars that do not fulfill the requirements acc. DIN 488 shall be calculated acc. Technical Report TR029, Equation (5.1).</li> <li>2) The partial safety factor <math>\gamma_{Ms,N}</math> for rebars that do not fulfill the requirements acc. DIN 488 shall be calculated acc. Technical Report TR029, Equation (3.3a).</li> <li>3) In absence of national regulations</li> <li>4) Explanation see Annex B1</li> <li>5) h concrete member thickness, <math>h_{ef}</math> effective anchorage depth</li> <li>6) The partial safety factor <math>\gamma_2 = 1,2</math> is included.</li> </ol>									
<b>ARVEX CV</b>						<b>Annex C2</b>			
<b>Design according to TR 029</b>									
Characteristic resistance under tension loads for rebars									

ARVEX CV with threaded rods			M 8	M 10	M 12	M 16	M 20	M 24	
<b>Steel failure without lever arm</b>									
Characteristic resistance, class 5.8	$V_{Rk,s}$	[kN]	9	15	21	39	61	88	
Characteristic resistance, class 8.8	$V_{Rk,s}$	[kN]	15	23	34	63	98	141	
Characteristic resistance, class 10.9	$V_{Rk,s}$	[kN]	18	29	42	79	123	156	
Characteristic resistance, A4-70	$V_{Rk,s}$	[kN]	13	20	30	55.0	86	124	
Characteristic resistance, HCR	$V_{Rk,s}$	[kN]	15	23	34	62.8	98	124	
<b>Steel failure with lever arm</b>									
Characteristic resistance, class 5.8	$M^0_{Rk,s}$	[Nm]	19	37	66	167	326	561	
Characteristic resistance, class 8.8	$M^0_{Rk,s}$	[Nm]	30.0	60	105	266	519	898	
Characteristic resistance, class 10.9	$M^0_{Rk,s}$	[Nm]	38	75	131	333	649	893	
Characteristic resistance, A4-70	$M^0_{Rk,s}$	[Nm]	26	53	92	233	454	625	
Characteristic resistance, HCR	$M^0_{Rk,s}$	[Nm]	30	60	105	266	519	786	
<b>Partial safety factor steel failure</b>									
grade 5.8 or 8.8	$\gamma_{Ms,V}^{1)}$	[-]	1,25						
grade 10.9	$\gamma_{Ms,V}^{1)}$	[-]	1,50						
A4-70	$\gamma_{Ms,V}^{1)}$	[-]	1,56						
HCR	$\gamma_{Ms,V}^{1)}$	[-]	1,25				1,75		
<b>Concrete pryout failure</b>									
Factor in equation (5.7) of Technical Report TR029 for the design of bonded anchors	k	[-]	2,0						
Partial safety factor	$\gamma_{Mcp}^{1)}$	[-]	1,5 <sup>2)</sup>						
<b>Concrete edge failure<sup>3)</sup></b>									
Partial safety factor	$\gamma_{Mc}^{1)}$	[-]	1,5 <sup>2)</sup>						

1) In absence of national regulations

2) The partial safety factor  $\gamma_2 = 1.0$  is included

3) Concrete edge failure see chapter 5.2.3.4 of Technical Report TR029

ARVEX CV

Design according to TR 029

Characteristic resistance under shear loads for threaded rods

Annex C3



ARVEX CV with rebar			Ø8	Ø10	Ø12	Ø14	Ø16	Ø20	Ø25
<b>Steel failure without lever arm</b>									
Characteristic shear resistance for rebar BSt 500 S acc. to DIN 488 <sup>1)</sup>	$V_{Rk,s}$	[kN]	14	22	31	42	55	86	135
Partial safety factor for rebar BSt 500 S acc. to DIN 488 <sup>2)</sup>	$\gamma_{Ms,V}^{3)}$	[-]	1,5						
<b>Steel failure with lever arm</b>									
Characteristic shear resistance for rebar BSt 500 S acc. to DIN 488 <sup>4)</sup>	$M^0_{Rk,s}$	[Nm]	33	65	112	178	265	518	1012
Partial safety factor for rebar BSt 500 S acc. to DIN 488 <sup>3)</sup>	$\gamma_{Ms,V}^{3)}$	[-]	1,5						
<b>Concrete pryout failure</b>									
Factor in equation (5.7) of Technical Report TR029 for the design of bonded anchors	k	[-]	2,0						
Partial safety factor	$\gamma_{Mcp}^{3)}$	[-]	1,5 <sup>5)</sup>						
<b>Concrete edge failure<sup>6)</sup></b>									
Partial safety factor	$\gamma_{Mc}^{3)}$	[-]	1,5 <sup>5)</sup>						

- 1) The characteristic shear resistance  $V_{Rk,s}$  for rebars that do not fulfill the requirements acc. DIN 488 shall be calculated acc. Technical Report TR029, Equation (5.6).
- 2) The partial safety factor  $\gamma_{Ms,N}$  for rebars that do not fulfill the requirements acc. DIN 488 shall be calculated acc. Technical Report TR029, Equation 3.3b or 3.3c.
- 3) In absence of national regulations
- 4) The characteristic bending resistance  $M^0_{Rk,s}$  for rebars that do not fulfill the requirements acc. DIN 488 shall be calculated acc. Technical Report TR029, Equation (5.6b).
- 5) The partial safety factor  $\gamma_2 = 1,0$  is included.
- 6) Concrete edge failure see chapter 5.2.3.4 of Technical Report TR029

ARVEX CV

Design according to TR 029

Characteristic resistance under shear loads for rebars

Annex C4

ARVEX CV with threaded rods			M 8	M 10	M 12	M 16	M 20	M 24
<b>Steel failure</b>								
Characteristic resistance, class 5.8	$N_{Rk,s}$	[kN]	18	29	42	79	123	177
Characteristic resistance, class 8.8	$N_{Rk,s}$	[kN]	29	46	67	126	196	282
Partial safety factor	$\gamma_{Ms,N}^{1)}$	[-]	1.50					
Characteristic resistance, class 10.9	$N_{Rk,s}$		36	58	84	157	245	353
Partial safety factor	$\gamma_{Ms,N}^{1)}$		1.40					
Characteristic resistance "A4 70"	$N_{Rk,s}$	[kN]	26	41	59	110	172	247
Partial safety factor	$\gamma_{Ms,N}^{1)}$	[-]	1.87					
Characteristic resistance "HCR"	$N_{Rk,s}$	[kN]	29	46	67	126	196	247
Partial safety factor	$\gamma_{Ms,N}^{1)}$	[-]	1.5					
<b>Combined Pull-out and Concrete cone failure</b>								
Diameter of threaded rod	d	[mm]	8	10	12	16	20	24
Characteristic bond resistance in non-cracked concrete C20/25								
Temperature range I <sup>2)</sup> : 40°C/24°C	$\tau_{Rk,uncr}$	[N/mm <sup>2</sup> ]	10.0	9.5	9.0	8.0	7.5	7.0
Temperature range II <sup>2)</sup> : 80°C/50°C	$\tau_{Rk,uncr}$	[N/mm <sup>2</sup> ]	9.0	8.0	7.5	7.0	6.5	6.0
Increasing factor for $\tau_{Rk,p}$ in non-cracked concrete	$\psi_c$	C30/37	1,12					
		C40/50	1,23					
		C50/60	1,30					
Characteristic bond resistance in cracked concrete C20/25								
Temperature range I <sup>2)</sup> : 40°C/24°C	$\tau_{Rk,cr}$	[N/mm <sup>2</sup> ]	- <sup>5)</sup>	- <sup>5)</sup>	3.5	3.5	- <sup>5)</sup>	- <sup>5)</sup>
Temperature range II <sup>2)</sup> : 80°C/50°C	$\tau_{Rk,cr}$	[N/mm <sup>2</sup> ]	- <sup>5)</sup>	- <sup>5)</sup>	3.0	3.0	- <sup>5)</sup>	- <sup>5)</sup>
Increasing factor for $\tau_{Rk}$ in cracked concrete	$\psi_c$	C30/37	1,04					
		C40/50	1,07					
		C50/60	1,09					
Factor according to CEN/TS 1992-4-5 Section 6.2.2	$\frac{k_8 \text{ non cracked concrete}}{k_8 \text{ cracked concrete}}$	[-]	10.1					
		[-]	7.2					
<b>Concrete cone failure</b>								
Factor according to CEN/TS 1992-4-5 Section 6.2.3	$k_{ucr}$	[-]	10.1					
		[-]	7.2					
Edge distance	$C_{cr,N}$	[-]	1,5 h <sub>ef</sub>					
Axial distance	$S_{cr,N}$	[-]	3,0 h <sub>ef</sub>					
<b>Splitting failure</b>								
Edge distance $C_{cr,sp}$ [mm] for	$h / h_{ef}^{3)} \geq 2,0$		1,0 h <sub>ef</sub>					
	$2,0 > h / h_{ef}^{3)} > 1,3$		4,6 h <sub>ef</sub> - 1,8 h					
	$h / h_{ef}^{3)} \leq 1,3$		2,26 h <sub>ef</sub>					
Spacing	$S_{cr,sp}$	[mm]	2 · C <sub>cr,sp</sub>					
Partial safety factor	$\gamma_{Mp} = \gamma_{Mc} = \gamma_{Msp}^{1)}$	[-]	1,5 <sup>4)</sup>	1,5 <sup>4)</sup>	1,5 <sup>4)</sup>	1,5 <sup>4)</sup>	1,5 <sup>4)</sup>	1,5 <sup>4)</sup>

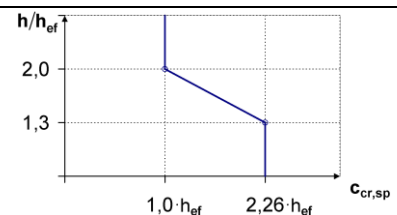

- 1) In absence of national regulations
- 2) Explanations, see Annex B1
- 3) h concrete member thickness, h<sub>ef</sub> effective anchorage depth
- 4) The partial safety factor  $\gamma_2 = 1,0$  is included
- 5) Not qualified in cracked concrete

ARVEX CV

Design according to CEN/TS 1992-4

Characteristic resistance under tension loads for threaded rods

Annex C5

ARVEX CV with rebar			Ø8	Ø10	Ø12	Ø14	Ø16	Ø20	Ø25
<b>Steel failure rebar</b>									
Characteristic resistance for rebar BSt 500 S acc. to DIN 488 <sup>1)</sup>	$N_{Rk,s}$	[kN]	28	43	62	85	111	173	270
Partial safety factor for rebar BSt 500 S acc. to DIN 488 <sup>2)</sup>	$\gamma_{Ms,N}$ <sup>3)</sup>	[-]	1,4						
<b>Combined Pull-out and Concrete cone failure</b>									
Diameter of rebar	d	[mm]	8	10	12	14	16	20	25
Characteristic bond resistance in non-cracked concrete C20/25									
Temperature range I <sup>4)</sup> : 40°C/24°C	$\tau_{Rk}$	[N/mm <sup>2</sup> ]	7,0	7,5	7,0	7,0	6,5	6,5	6,0
Temperature range II <sup>4)</sup> : 80°C/50°C	$\tau_{Rk}$	[N/mm <sup>2</sup> ]	6.5	6.5	6,0	6,0	6,0	5,5	5,5
Increasing factor for $\tau_{Rk,p}$ in non-cracked concrete	$\psi_c$	C30/37	1,12						
		C40/50	1,23						
		C50/60	1,30						
Factor according to CEN/TS 1992-4-5 Section 6.2.2	$k_8$ non cracked concrete	[-]	10.1						
<b>Concrete cone failure</b>									
Factor according to CEN/TS 1992-4-5 Section 6.2.2	$k_{ucr}$	[-]	10.1						
<b>Splitting failure</b>									
Edge distance $c_{cr,sp}$ [mm] for	$h / h_{ef}^{5)} \geq 2,0$		<b>1,0 <math>h_{ef}</math></b>						
	$2,0 > h / h_{ef}^{5)} > 1,3$		<b>4,6 <math>h_{ef}</math> - 1,8 h</b>						
	$h / h_{ef}^{5)} \leq 1,3$		<b>2,26 <math>h_{ef}</math></b>						
Spacing	$s_{cr,sp}$	[mm]	<b>2 <math>c_{cr,sp}</math></b>						
Partial safety factor	$\gamma_{Mp} = \gamma_{Mc} = \gamma_{Msp}$ <sup>3)</sup>	[-]	1,8 <sup>6)</sup>	1,8 <sup>6)</sup>	1,8 <sup>6)</sup>	1,8 <sup>6)</sup>	1,8 <sup>6)</sup>	1,8 <sup>6)</sup>	1,8 <sup>6)</sup>
<p>1) The characteristic tension resistance <math>N_{Rk,s}</math> for rebars that do not fulfill the requirements acc. DIN 488 shall be calculated acc. Technical Report TR029, Equation (5.1).</p> <p>2) The partial safety factor <math>\gamma_{Ms,N}</math> for rebars that do not fulfill the requirements acc. DIN 488 shall be calculated acc. Technical Report TR029, Equation (3.3a).</p> <p>3) In absence of national regulations</p> <p>4) Explanation see Annex B1</p> <p>5) h concrete member thickness, <math>h_{ef}</math> effective anchorage depth</p> <p>6) The partial safety factor <math>\gamma_2 = 1,2</math> is included.</p>									
<b>ARVEX CV</b>						<b>Annex C6</b>			
<b>Design according to CEN/TS 1992-4</b>									
Characteristic resistance under tension loads for rebars									

ARVEX CV with threaded rods			M 8	M 10	M 12	M 16	M 20	M 24
<b>Steel failure without lever arm</b>								
Characteristic resistance, class 5.8	$V_{Rk,s}$ [kN]		9	15	21	39	61	88
Characteristic resistance, class 8.8	$V_{Rk,s}$ [kN]		15	23	34	63	98	141
Characteristic resistance, class 10.9	$V_{Rk,s}$ [kN]		18	29	42	79	123	156
Characteristic resistance, A4-70	$V_{Rk,s}$ [kN]		13	20	30	55.0	86	124
Characteristic resistance, HCR	$V_{Rk,s}$ [kN]		15	23	34	62.8	98	124
<b>Steel failure with lever arm</b>								
Characteristic resistance, class 5.8	$M^0_{Rk,s}$ [Nm]		19	37	66	167	326	561
Characteristic resistance, class 8.8	$M^0_{Rk,s}$ [Nm]		30.0	60	105	266	519	898
Characteristic resistance, class 10.9	$M^0_{Rk,s}$ [Nm]		38	75	131	333	649	893
Characteristic resistance, A4-70	$M^0_{Rk,s}$ [Nm]		26	53	92	233	454	625
Characteristic resistance, HCR	$M^0_{Rk,s}$ [Nm]		30	60	105	266	519	786
<b>Partial safety factor steel failure</b>								
grade 5.8 or 8.8	$\gamma_{Ms,V}^{1)}$ [-]		1,25					
grade 10.9	$\gamma_{Ms,V}^{1)}$ [-]		1,50					
A4-70	$\gamma_{Ms,V}^{1)}$ [-]		1,56					
HCR	$\gamma_{Ms,V}^{1)}$ [-]		1,25					1,75
<b>Concrete pryout failure</b>								
Factor according to CEN/TS 1992-4-5 Section 4.3.3	$k_3$ [-]		2,0					
Partial safety factor	$\gamma_{Mcp}^{1)}$ [-]		1,5 <sup>2)</sup>					
<b>Concrete edge failure</b>								
Partial safety factor	$\gamma_{Mc}^{1)}$ [-]		1,5 <sup>2)</sup>					

1) In absence of national regulations

2) The partial safety factor  $\gamma_2 = 1.0$  is included

ARVEX CV

Design according to CEN/TS 1992-4

Characteristic resistance under shear loads for threaded rods

Annex C7

ARVEX CV with rebar			Ø8	Ø10	Ø12	Ø14	Ø16	Ø20	Ø25
<b>Steel failure <sup>without</sup> lever arm</b>									
Characteristic shear resistance for rebar BSt 500 S acc. to DIN 488 <sup>1)</sup>	$V_{Rk,s}$	[kN]	14	22	31	42	55	86	135
Partial safety factor for rebar BSt 500 S acc. to DIN 488 <sup>2)</sup>	$\gamma_{Ms,V}^{3)}$	[-]	1,5						
<b>Steel failure with lever arm</b>									
Characteristic shear resistance for rebar BSt 500 S acc. to DIN 488 <sup>1)</sup>	$M^0_{Rk,s}$	[Nm]	33	65	112	178	265	518	1012
Partial safety factor for rebar BSt 500 S acc. to DIN 488 <sup>2)</sup>	$\gamma_{Ms,V}^{3)}$	[-]	1,5						
<b>Concrete pryout failure</b>									
Factor according to CEN/TS 1992-4-5 Section 4.3.3	$k_3$	[-]	2,0						
Partial safety factor	$\gamma_{Mcp}^{3)}$	[-]	1,5 <sup>5)</sup>						
<b>Concrete edge failure</b>									
Partial safety factor	$\gamma_{Mc}^{3)}$	[-]	1,5 <sup>5)</sup>						

- 1) The characteristic shear resistance  $V_{Rk,s}$  for rebars that do not fulfill the requirements acc. DIN 488 shall be calculated acc. Technical Report TR029, Equation (5.6).
- 2) The partial safety factor  $\gamma_{Ms,N}$  for rebars that do not fulfill the requirements acc. DIN 488 shall be calculated acc. Technical Report TR029, Equation 3.3b or 3.3c.
- 3) In absence of national regulations
- 4) The characteristic bending resistance  $M^0_{Rk,s}$  for rebars that do not fulfill the requirements acc. DIN 488 shall be calculated acc. Technical Report TR029, Equation (5.6b).
- 5) The partial safety factor  $\gamma_2 = 1,0$  is included.

ARVEX CV

Design according to CEN/TS 1992-4

Characteristic resistance under shear loads for rebars

Annex C8

### Displacement under tension load <sup>1)</sup>

ARVEX CV with threaded rods		M8	M10	M12	M16	M20	M24
<b>Non cracked concrete temperature range I: 40°C / 24°C</b>							
Displacement	$\delta_{N0}$ [mm/(N/mm <sup>2</sup> )]	0,03	0,03	0,04	0,05	0,06	0,07
Displacement	$\delta_{N\infty}$ [mm/(N/mm <sup>2</sup> )]	0,07	0,09	0,10	0,13	0,17	0,20
<b>Non-cracked concrete temperature range II: 80°C / 50°C</b>							
Displacement	$\delta_{N0}$ [mm/(N/mm <sup>2</sup> )]	0,04	0,04	0,05	0,07	0,08	0,10
Displacement	$\delta_{N\infty}$ [mm/(N/mm <sup>2</sup> )]	0,10	0,13	0,15	0,19	0,23	0,28
<b>Cracked concrete temperature range I: 40°C / 24°C</b>							
Displacement	$\delta_{N0}$ [mm/(N/mm <sup>2</sup> )]	-	-	0,12	0,09	-	-
Displacement	$\delta_{N\infty}$ [mm/(N/mm <sup>2</sup> )]	-	-	0,64	0,55	-	-
<b>Cracked concrete temperature range II: 80°C / 50°C</b>							
Displacement	$\delta_{N0}$ [mm/(N/mm <sup>2</sup> )]	-	-	0,17	0,13	-	-
Displacement	$\delta_{N\infty}$ [mm/(N/mm <sup>2</sup> )]	-	-	0,90	0,78	-	-

ARVEX CV with rebar		Ø8	Ø10	Ø12	Ø14	Ø16	Ø20	Ø25
<b>Temperature range I: 40°C / 24°C</b>								
Displacement	$\delta_{N0}$ [mm/(N/mm <sup>2</sup> )]	0,03	0,03	0,04	0,04	0,05	0,06	0,07
Displacement	$\delta_{N\infty}$ [mm/(N/mm <sup>2</sup> )]	0,07	0,09	0,10	0,12	0,13	0,17	0,20
<b>Temperature range II: 80°C / 50°C</b>								
Displacement	$\delta_{N0}$ [mm/(N/mm <sup>2</sup> )]	0,04	0,04	0,05	0,06	0,07	0,08	0,10
Displacement	$\delta_{N\infty}$ [mm/(N/mm <sup>2</sup> )]	0,10	0,13	0,15	0,17	0,19	0,23	0,29

- <sup>1)</sup> Calculation of displacement under service load:  $\tau_{Sd}$  design value of bond stress  
 Displacement under short term loading =  $\delta_{N0} \cdot \tau_{Sd}/1,4$   
 Displacement under long term loading =  $\delta_{N\infty} \cdot \tau_{Sd}/1,4$

### Displacement under shear load <sup>2)</sup>

ARVEX CV with threaded rods		M8	M10	M12	M16	M20	M24
Displacement	$\delta_{V0}$ [mm/kN]	0,06	0,06	0,05	0,04	0,04	0,03
Displacement	$\delta_{V\infty}$ [mm/kN]	0,09	0,08	0,08	0,06	0,06	0,05

ARVEX CV with rebar		Ø8	Ø10	Ø12	Ø14	Ø16	Ø20	Ø25
Displacement	$\delta_{V0}$ [mm/kN]	0,06	0,05	0,05	0,04	0,04	0,04	0,03
Displacement	$\delta_{V\infty}$ [mm/kN]	0,09	0,08	0,07	0,06	0,06	0,05	0,05

- <sup>2)</sup> Calculation of displacement under service load:  $V_{Sd}$  design value of shear load.  
 Displacement under short term loading =  $\delta_{V0} \cdot V_{Sd}/1,4$   
 Displacement under long term loading =  $\delta_{V\infty} \cdot V_{Sd}/1,4$

ARVEX CV

Design

Anchor displacements

Annex C9