



**INSTITUTO DE CIENCIAS
DE LA CONSTRUCCIÓN
EDUARDO TORROJA**

C/ Serrano Galvache n. 4 28033 Madrid (Spain)
Tel.: (34) 91 302 04 40
direccion.ietcc@csic.es <https://dit.ietcc.csic.es>



European Technical Assessment

ETA 24/0051 of 18/01/2024

English translation prepared by IETcc. Original version in Spanish language

General Part

Technical Assessment Body issuing the ETA designated according to Art. 29 of Regulation (EU) 305/2011:

Instituto de Ciencias de la Construcción Eduardo Torroja (IETcc)

**Trade name of the construction product:
Product family to which the construction product belongs:**

ARVEX SS concrete screw

Concrete screw of sizes 7.5, 10.5, 12.5, 14.2 and 16.5 for use in cracked and non-cracked concrete.

Manufacturer:

ARVEX GROBELNY Sp. z.o.o.
ul. Makuszyńskiego 4, 30-969 Kraków, Poland
website:www.arvex.pl

Manufacturing plants:

Production plant no. 11

This European Technical Assessment contains:

29 pages including 4 annexes which form an integral part of this assessment.

This European Technical Assessment is issued in accordance with regulation (EU) No 305/2011, on the basis of:

European Technical Assessment EAD 330232-01-0601 "Mechanical Fasteners for use in concrete", ed. December 2019



English translation prepared by IETcc

This European Technical Assessment is issued by the Technical Assessment Body in its official language. Translations of this European Technical Assessment in other languages shall fully correspond to the original issued document and should be identified as such.

This European Technical Assessment may be withdrawn by the issuing Technical Assessment Body, in particular pursuant to information by the Commission according to article 25 (3) of Regulation (EU) No 305/2011.

Código seguro de Verificación : GEN-3be1-ca03-a598-4c56-78ad-a899-5bfa-d337 | Puede verificar la integridad de este documento en la siguiente dirección : <https://portafirmas.redsara.es/pf/valida>

CSV : GEN-3be1-ca03-a598-4c56-78ad-a899-5bfa-d337

DIRECCIÓN DE VALIDACIÓN : <https://portafirmas.redsara.es/pf/valida>

FIRMANTE(1) : ANGEL CASTILLO TALAVERA | FECHA : 13/03/2024 13:00 | Sin acción específica



SPECIFIC PART

1. Technical description of the product

The ARVEX SS concrete screw is a type of anchor made of carbon steel and stainless steel (bimetal). The anchor is made of carbon steel for sizes 7.5, 10.5, 12.5, 14.2 and 16.5 and of stainless steel for sizes 7.5, 10.5, 12.5. Both of them are screwed into a predrilled cylindrical drill hole. The special thread of the anchor cuts an internal thread into the member while setting. The anchorage is characterised by mechanical interlock in the special thread.

The product and its installation description are shown in annexes A.

2. Specification of the intended use in accordance with the applicable European Assessment Document.

The performances given in section 3 are only valid if the anchor is used in compliance with the specifications and conditions given in annex B.

The verifications and assessment methods on which this European Technical Assessment is based lead to the assumption of a working life of the anchor of at least 50 years. The indications given on the working life cannot be interpreted as a guarantee given by the producer, but are to be regarded only as a means to choosing the right products in relation to the expected economically reasonable working life of the works.

3. Performance of the product and references to the methods used for its assessment

3.1 Mechanical resistance and stability (BWR 1)

Essential characteristic	Performance
Static or quasi static actions	See annexes C1 to C7
Essential characteristic and displacements for seismic performance categories C1 and C2	See annexes C8 and C9

3.2 Safety in case of fire (BWR 2)

Essential characteristic	Performance
Reaction to fire	Anchorage satisfy requirements for class A1
Resistance to fire	See annex D

4. Assessment and verification of constancy of performance (hereinafter AVCP) system applied, with reference to its legal base

The applicable European legal act for the system of Assessment and Verification of Constancy of Performances (see annex V of Regulation (EU) No 305/2011) is 96/582/EC.

The system to be applied is 1.



5. Technical details necessary for the implementation of the AVCP system, as provided for in the applicable European Assessment Document.

The technical details necessary for the implementation of the AVCP system are laid down in the quality plan deposited at Instituto de Ciencias de la Construcción Eduardo Torroja.



Instituto de Ciencias de la Construcción Eduardo Torroja
CONSEJO SUPERIOR DE INVESTIGACIONES CIENTÍFICAS











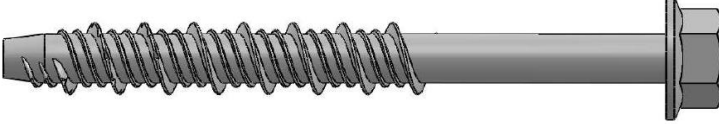

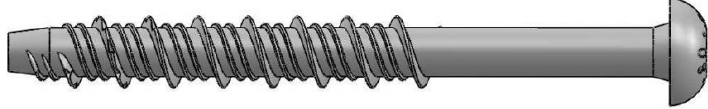
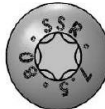
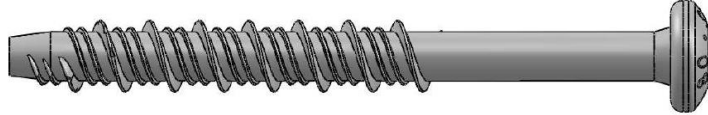

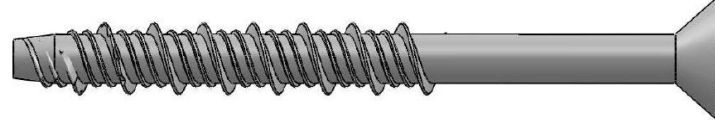
C/ Serrano Galvache n.º 4. 28033 Madrid.
Tel: (+34) 91 302 04 40
<https://dit.ietcc.csic.es>

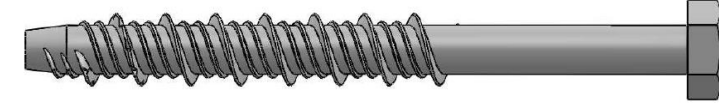

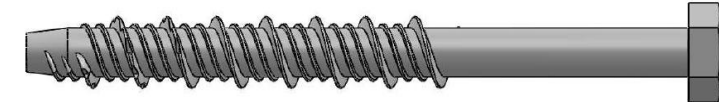

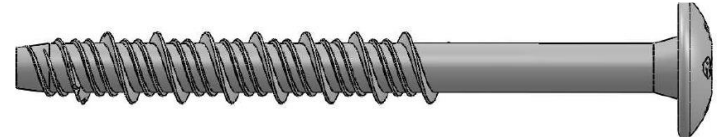

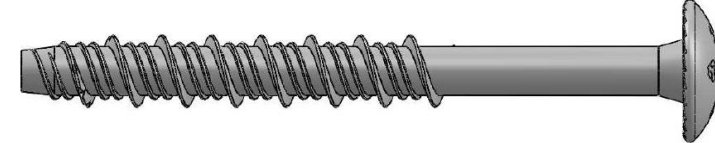







On behalf of the Instituto de Ciencias de la Construcción Eduardo Torroja
Madrid, 18th of January 2024

Mr. Ángel Castillo Talavera
Director IETcc - CSIC

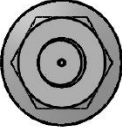

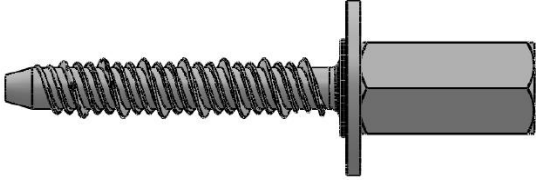
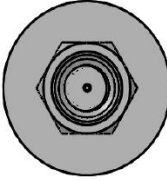
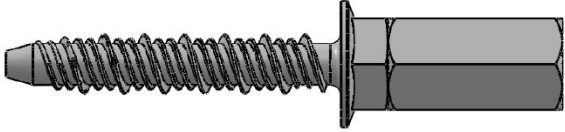
Product and identification	
	 SSW
	 SSR
	 SSP
	 SSK 7.5 08
	 SSH
	 SSX
	 SST 7.5 08
	 SSN 7.5 08
ARVEX SS concrete screw	
Product description	Annex A1
Identification	

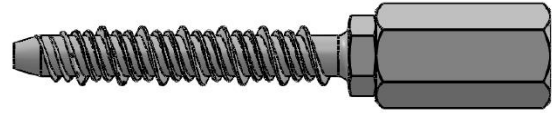

		SSD
		SSI
		SSF
		SSO
		SSU
		SSG
		SSQ
		SSV
ARVEX SS concrete screw		Annex A2
Product description		
Identification		



English translation prepared by IETcc

Código seguro de Verificación : GEN-3be1-ca03-a598-4c56-78ad-a899-5bfa-d337 | Puede verificar la integridad de este documento en la siguiente dirección : <https://portafirmas.redsara.es/pf/valida>

		SSG2
ARVEX SS concrete screw		Annex A3
Product description		
Identification		



English translation prepared by IETcc

Marking/Identification on anchor:

- Logo
- Outer diameter
- Length
- Anchor type:
 - Hex head with washer SSW
 - Round head SSR
 - Pan head SSP
 - Countersunk head SSK
 - Hex head SSH
 - Hex head, hexalobular recess SSX
 - Truss head SST
 - Truss head with underhead ribs SSN
 - Connection thread with hexagon drive SSD
 - Internal thread SSI
 - Flat washer head with connection thread SSF
 - Hex washer head with connection thread SSO
 - Hex head with connection thread SSU
 - SSF flex with coupler nut SSG
 - SSO flex with coupler nut SSQ
 - SSU flex with coupler nut SSV
 - SSG flex without washer SSG2

ARVEX SS concrete screw

Product description

Identification and materials

Annex A4



SS Carbon Steel

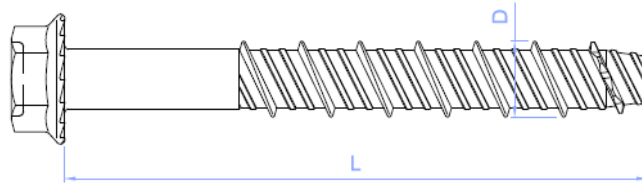
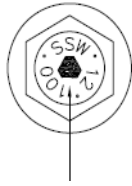

Head marking:
Identifying mark of producer: ARVEX
Outer Diameter of Thread: e.g. D=12.5
Length L: e.g. 100 mm
Material: Carbon Steel

SS Bimetal

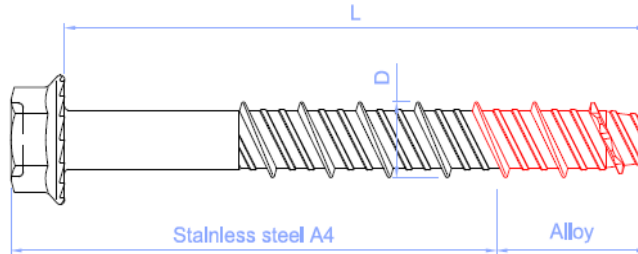
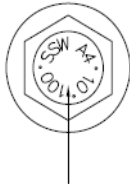

Head marking:
Identifying mark of producer: ARVEX
Drill bit size: e.g. 10 mm
Length L: e.g. 100 mm
Material: A4 Stainless Steel

Table A1: Materials

Item	Designation	SS concrete screw (SS Carbon Steel)	SS concrete screw (SS Bimetal)
1	Anchor Body	Carbon steel wire rod cold forged. Allowed coatings: <ul style="list-style-type: none"> Zinc plated $\geq 5 \mu\text{m}$ ISO 4042 Zn5 Silver ruspert 1000/2000hours ISO9227 Zinc flake $\geq 5 \mu\text{m}$ EN 10683 Mechanical plated $\geq 30 \mu\text{m}$ EN ISO 12683 Zn 40 M(Fe) 	Shaft and head: stainless steel grade A4 ISO 3506-1 Tip: hardened carbon steel

ARVEX SS concrete screw

Product description

Identification and materials

Annex A5



Installed condition

- h_{ef} : Effective anchorage depth
- h_1 : Depth of drilled hole
- h_{nom} : Overall anchor embedment depth in the concrete
- h_{min} : Minimum thickness of concrete member
- t_{fix} : Thickness of fixture
- d_0 : Nominal diameter of drill bit
- d_f : Diameter of clearance hole in fixture
- t_{fix} : Fixture thickness

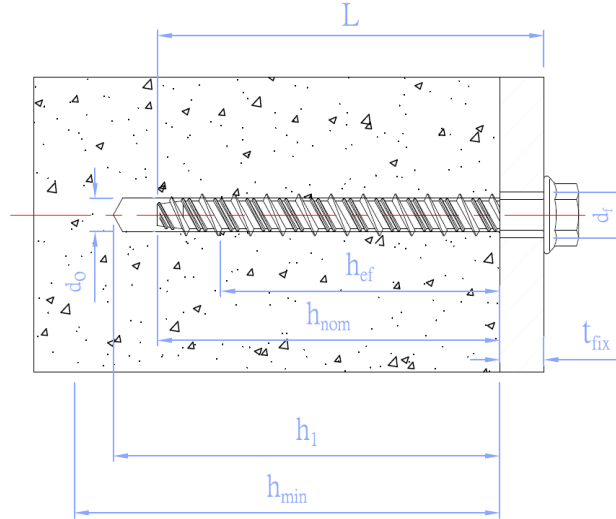

Drawing A1. Installed condition for anchors SSW, SSR, SSP, SSK, SSH, SSX, SST, SSN

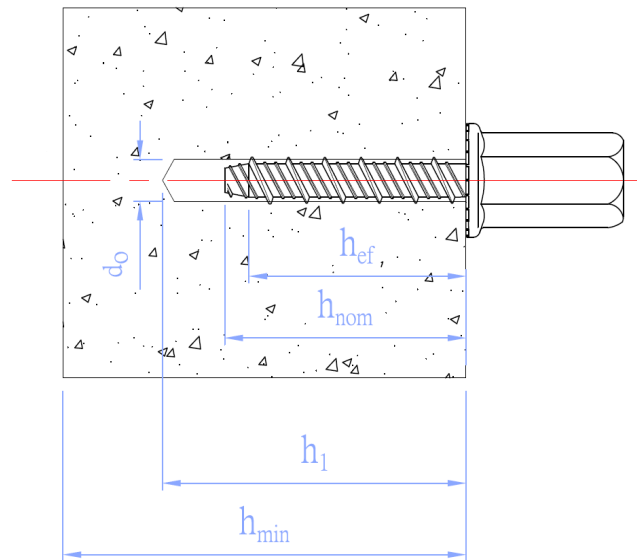

Drawing A2. Installed condition for anchors SSD, SSI, SSF, SSO, SSU, SSG, SSQ, SSV, SSG2

ARVEX SS concrete screw	Annex A6
Product description	
Installed condition	



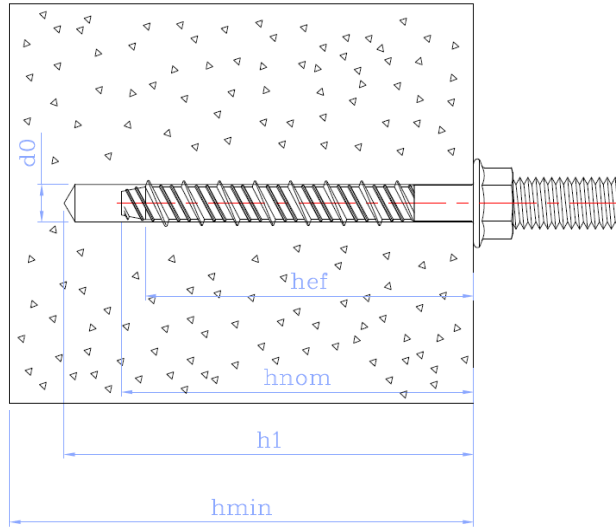

Drawing A3. Installed condition for anchors SSD, SSI, SSF, SSO, SSU, SSG, SSQ, SSV, SSG2,

ARVEX SS concrete screw	Annex A7
Product description	
Installed condition	



Specification of intended use

Anchorage subjected to:

- Static or quasi static loads: all sizes and embedment depths.
- Fire exposure up to 120 minutes
- Performances C1 and C2 (seismic) for SS Carbon Steel screws as shown below:

Size	7.5		10.5		12.5			14.2		16.5	
h_{nom}	40	55	50	60	60	70	85	75	105	75	110
C1	✓	✓		✓			✓		✓		✓
C2				✓			✓		✓		✓

Base materials:

- Reinforced and unreinforced normal weight concrete without fibers according to EN 206:2013 + A1:2016.
- Strength classes C20/25 to C50/60 according to EN 206:2013 + A1:2016.
- Cracked and uncracked concrete.

Use conditions (environmental conditions):

- The anchor SS Carbon Steel shall be used in dry internal conditions.
- The anchor SS Bimetal shall be used in dry internal conditions, external atmospheric exposure (including industrial and marine environment) or permanent internal damp conditions if there are no particular aggressive conditions. Such particular aggressive conditions are e.g., permanent, alternating immersion in seawater or the splash zone of seawater, chloride atmosphere of indoor swimming pools or atmosphere with extreme chemical pollution (e.g., in desulphurization plants or road tunnels where de-icing materials are used). Atmospheres under Corrosion Resistance Class CRC III according to EN 1993-1-4:2006+A1:2015 annex A.
- The anchor may be used for anchorages with requirements related to resistance to fire.

Design:

- Anchorages are designed under the responsibility of an engineer experienced in anchorages and concrete.
- Verifiable calculation rules and drawings are prepared taking into account of the loads to be attached. The position of the anchor is indicated on the design drawings (e.g. position of the anchor relative to reinforcement or to supports, etc.)
- Anchorages under static or quasi-static loads are designed for design Method A in accordance with EN 1992-4:2018
- Anchorages under seismic actions are designed in accordance with EN 1992-4:2018. Anchorages shall be positioned outside of critical regions (e.g. plastic hinges) of the concrete structure. Fastening in stand-off installation or with grout layer are not allowed.
- Anchorages under fire exposure are designed in accordance with EN 1992-4:2018. It must be ensured that local spalling of the concrete cover does not occur.
- Shear assessment only covers the shear force induced by the fixed piece, i.e. the piece located between the anchor head and the concrete block (piece contained in t_{fix} , see Drawing A1).

ARVEX SS concrete screw

Intended use

Specifications

Annex B1



English translation prepared by IETcc

Código seguro de Verificación : GEN-3be1-ca03-a598-4c56-78ad-a899-5bfa-d337 | Puede verificar la integridad de este documento en la siguiente dirección : <https://portafirmas.redsara.es/pf/valida>

Installation:

- Hammer drilling only.
- Anchor installation carried out by appropriately qualified personal and under the supervision of the person responsible for technical matters of the site.
- In case of aborted hole: new drilling at a minimum distance away of twice the depth of aborted hole or smaller distance if the aborted hole is filled with high strength mortar and if under shear or oblique tension load it is not the direction of the load application.
- After installation further turning of the anchor is not possible.
- The head of the anchor is supported on the fixture, as it is shown in Drawing A1, and it must not be damaged.

Installation process

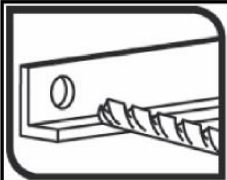
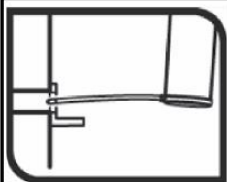
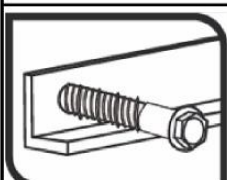
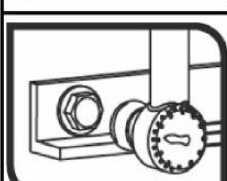
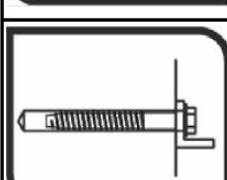
	<p>1. DRILL Drill a hole into the base material of correct diameter and depth by using a carbide drill bit in rotary plus hammer mode.</p>
	<p>2. BLOW and CLEAN Remove dust and debris from hole and loose particles left from drilling by using hand pump, compressed air or vacuum.</p>
	<p>3. INSTALL Hold screw anchor perpendicular direction into the base material through fixtures.</p>
	<p>4. APPLY TORQUE Select a power impact wrench or a torque wrench (e.g: Bosch GDS 18E, power input: 500 W; torque: 50-250 Nm). Power impact wrench does not exceed over torque Tinst.</p>
	<p>5. CHECK The head must be undamaged and in contact with the fixture. When screw head attach fixture or concrete surface firmly, further turning of the head is unnecessary.</p>

ARVEX SS concrete screw

Intended use

Specifications and installation procedure

Annex B2



Table B1: Installation parameters for SS Carbon Steel

Installation parameters SS Carbon Steel			Performance							
			7.5			10.5		12.5		
h_{nom}	Overall anchor embedment depth in the concrete:	[mm]	40	55		50	60	60	70	85
d_0	Nominal diameter of drill bit:	[mm]	6			8		10		
d_f	Diameter of clearance hole in fixture:	[mm]	9			12		14		
d_s	Outer diameter of the thread:	[mm]	7.5			10.5		12.5		
d_k	Core diameter:	[mm]	5.4			7.2		9.0		
h_{min}	Minimum thickness of concrete member:	[mm]	100	80	100	100	100	100	105	130
h_1	Depth of drilled hole:	[mm]	50	65		60	70	70	85	100
h_{ef}	Effective anchorage depth:	[mm]	29	42		37	45	44	52	65
T_{ins}	Installation torque:	[Nm]	15			25		50		
t_{fix}	Thickness of fixture ¹⁾ :	[mm]	L-40	L-55		L-50	L-60	L-60	L-70	L-85
s_{min}	Minimum allowable spacing:	[mm]	35	50	45	35	50	50	60	70
c_{min}	Minimum allowable edge distance:	[mm]	35	35	45	35	50	40	60	60

¹⁾ L = Total length of the fastener

Installation parameters SS Carbon Steel			Performance			
			14.2		16.5	
h_{nom}	Overall anchor embedment depth in the concrete:	[mm]	75	105	75	110
d_0	Nominal diameter of drill bit:	[mm]	12		14	
d_f	Diameter of clearance hole in fixture:	[mm]	16		18	
d_s	Outer diameter of the thread:	[mm]	14.2		16.5	
d_k	Core diameter:	[mm]	11.3		13.6	
h_{min}	Minimum thickness of concrete member:	[mm]	120	170	120	175
h_1	Depth of drilled hole:	[mm]	90	120	90	130
h_{ef}	Effective anchorage depth:	[mm]	57	82	56	86
T_{ins}	Installation torque:	[Nm]	60		80	
t_{fix}	Thickness of fixture ¹⁾ :	[mm]	L-75	L-105	L-75	L-110
s_{min}	Minimum allowable spacing:	[mm]	70	70	75	100
c_{min}	Minimum allowable edge distance:	[mm]	45	45	45	100

¹⁾ L = Total length of the fastener

ARVEX SS concrete screw

Performances

Installation parameters

Annex B3



Table B2: Installation parameters for SS Bimetal

Installation parameters SS Bimetal			Performance					
			7.5		10.5		12.5	
h_{nom}	Overall anchor embedment depth in the concrete:	[mm]	40	55	50	60	70	85
d_0	Nominal diameter of drill bit:	[mm]	6		8		10	
d_f	Diameter of clearance hole in fixture:	[mm]	9		12		14	
d_s	Outer diameter of the thread:	[mm]	7.5		10.5		12.5	
d_k	Core diameter:	[mm]	5.2		7.3		9.3	
h_{min}	Minimum thickness of concrete member:	[mm]	100	100	100	100	105	130
h_1	Depth of drilled hole:	[mm]	50	65	60	70	85	100
h_{ef}	Effective anchorage depth:	[mm]	29	42	37	45	52	65
T_{ins}	Installation torque:	[Nm]	15	20	25		50	
t_{fix}	Thickness of fixture ¹⁾ :	[mm]	L-40	L-55	L-50	L-60	L-70	L-85
s_{min}	Minimum allowable spacing:	[mm]	35	35	35	50	60	70
c_{min}	Minimum allowable edge distance:	[mm]	35	35	35	50	60	60

¹⁾ L = Total length of the fastener

ARVEX SS concrete screw

Performances

Installation parameters

Annex B4



Table C1: Characteristic values to tension loads for SS Carbon Steel

Characteristic values of resistance to tension loads of design method A			Performance						
			7.5		10.5		12.5		
h_{nom}	Overall anchor embedment depth in the concrete:	[mm]	40	55	50	60	60	70	85
Tension loads: steel failure									
$N_{Rk,s}$	Tension steel characteristic resistance:	[kN]	18.7		32.7		51.2		
γ_{Ms}	Partial safety factor: ¹⁾	[-]	1.5		1.5		1.5		
Tension loads: pull-out failure in concrete									
$N_{Rk,p,ucr}$	Tension characteristic resistance in C20/25 uncracked concrete:	[kN]	6.0	9.0	12.5 ²⁾	12.0 ²⁾	22.0 ²⁾	20.0 ²⁾	34.0 ²⁾
$N_{Rk,p,cr}$	Tension characteristic resistance in C20/25 cracked concrete:	[kN]	3.0	6.0	6.0	9.0	14.0 ²⁾	12.0	24.0 ²⁾
ψ_c	C30/37	[-]	1.16	1.22	1.16	1.08	1.14	1.04	1.18
ψ_c	C40/45	[-]	1.29	1.41	1.28	1.15	1.25	1.07	1.33
ψ_c	C50/60	[-]	1.40	1.55	1.39	1.19	1.34	1.09	1.46
Tension loads: concrete cone and splitting failure									
γ_{ins}	Installation safety factor: ¹⁾	[-]	1.2	1.2	1.2	1.2	1.2	1.2	1.0
h_{ef}	Effective embedment depth:	[mm]	29	42	37	45	44	52	65
$k_{ucr,N}$	Factor for uncracked concrete:	[-]	11.0						
$N^0_{Rk,c,ucr}$	Tension characteristic resistance in C20/25 uncracked concrete: ³⁾	[kN]	7.7	13.4	11.1	14.8	14.4	18.4	25.8
$k_{cr,N}$	Factor for cracked concrete:	[-]	7.7						
$N^0_{Rk,c,cr}$	Tension characteristic resistance in C20/25 cracked concrete: ³⁾	[kN]	5.4	9.4	7.8	10.4	10.1	12.9	18.0
$s_{cr,N}$	Critical spacing:	[mm]	3.0 x h_{ef}						
$c_{cr,N}$	Critical edge distance:	[mm]	1.5 x h_{ef}						
$s_{cr,sp}$	Critical spacing (splitting):	[mm]	3.0 x h_{ef}						
$c_{cr,sp}$	Critical edge distance (splitting):	[mm]	1.5 x h_{ef}						

¹⁾ In absence of other national regulations
²⁾ Pull-out failure is not decisive ($N^0_{Rk,c} < N_{Rk,p}$)
³⁾ Equation 7.2 from EN 1992-4:2018

ARVEX SS concrete screw

Performances

Characteristic values for tension loads

Annex C1



Table C1: Characteristic values to tension loads for SS Carbon Steel (continuation)

Characteristic values of resistance to tension loads of design method A			Performance			
			14.2		16.5	
h_{nom}	Overall anchor embedment depth in the concrete:	[mm]	75	105	75	110
Tension loads: steel failure						
$N_{Rk,s}$	Tension steel characteristic resistance:	[kN]	80.6		115.9	
γ_{Ms}	Partial safety factor: ¹⁾	[-]	1.5		1.5	
Tension loads: pull-out failure in concrete						
$N_{Rk,p,ucr}$	Tension characteristic resistance in C20/25 uncracked concrete:	[kN]	24.0 ²⁾	40.0 ²⁾	30.0 ²⁾	40.0 ²⁾
$N_{Rk,p,cr}$	Tension characteristic resistance in C20/25 cracked concrete:	[kN]	19.0 ²⁾	32.0 ²⁾	20.0 ²⁾	30.0 ²⁾
ψ_c	C30/37	[-]	1.10	1.08	1.13	1.04
ψ_c	C40/45	[-]	1.17	1.15	1.24	1.07
ψ_c	C50/60	[-]	1.23	1.20	1.33	1.09
Tension loads: concrete cone and splitting failure						
γ_{ins}	Installation safety factor: ¹⁾	[-]	1.2	1.0	1.2	1.0
h_{ef}	Effective embedment depth:	[mm]	57	82	56	86
$k_{ucr,N}$	Factor for uncracked concrete:	[-]	11.0			
$N^0_{Rk,c,ucr}$	Tension characteristic resistance in C20/25 uncracked concrete: ³⁾	[kN]	21.2	36.5	20.6	39.2
$k_{cr,N}$	Factor for cracked concrete:	[-]	7.7			
$N^0_{Rk,c,cr}$	Tension characteristic resistance in C20/25 cracked concrete: ³⁾	[kN]	14.8	25.6	14.4	27.5
$s_{cr,N}$	Critical spacing:	[mm]	3.0 x h_{ef}			
$c_{cr,N}$	Critical edge distance:	[mm]	1.5 x h_{ef}			
$s_{cr,sp}$	Critical spacing (splitting):	[mm]	3.0 x h_{ef}			
$c_{cr,sp}$	Critical edge distance (splitting):	[mm]	1.5 x h_{ef}			

- ¹⁾ In absence of other national regulations
²⁾ Pull-out failure is not decisive ($N^0_{Rk,c} < N_{Rk,p}$)
³⁾ Equation 7.2 from EN 1992-4:2018

ARVEX SS concrete screw

Performances

Characteristic values for tension loads

Annex C2



Table C2: Characteristic values to tension loads for SS Bimetal

Characteristic values of resistance to tension loads of design method A		Performance					
		7.5		10.5		12.5	
h_{nom}	Overall anchor embedment depth in the concrete: [mm]	40	55	50	60	70	85
Tension loads: steel failure							
$N_{Rk,s}$	Tension steel characteristic resistance: [kN]	17.0		33.5		54.3	
γ_{Ms}	Partial safety factor: ¹⁾ [-]	1.5		1.5		1.5	
Tension loads: pull-out failure in concrete							
$N_{Rk,p,ucr}$	Tension characteristic resistance in C20/25 uncracked concrete: [kN]	6.0	13.0 ²⁾	11.0 ²⁾	17.0 ²⁾	22.0 ²⁾	32.0 ²⁾
$N_{Rk,p,cr}$	Tension characteristic resistance in C20/25 cracked concrete: [kN]	2.0	11.0 ²⁾	7.5 ²⁾	12.0 ²⁾	17.0 ²⁾	24.0 ²⁾
ψ_c	C30/37 [-]	1.09	1.11	1.09	1.12	1.09	1.13
ψ_c	C40/45 [-]	1.16	1.20	1.16	1.21	1.16	1.23
ψ_c	C50/60 [-]	1.22	1.27	1.21	1.28	1.22	1.31
Tension loads: concrete cone and splitting failure							
γ_{ins}	Installation safety factor: ¹⁾ [-]	1.2	1.2	1.2	1.2	1.2	1.2
h_{ef}	Effective embedment depth: [mm]	29	42	37	45	52	65
$k_{ucr,N}$	Factor for uncracked concrete: [-]	11.0					
$N_{Rk,c,ucr}^0$	Tension characteristic resistance in C20/25 uncracked concrete: ³⁾ [kN]	7.7	13.4	11.1	14.8	18.4	25.8
$k_{cr,N}$	Factor for cracked concrete: [-]	7.7					
$N_{Rk,c,cr}^0$	Tension characteristic resistance in C20/25 cracked concrete: ³⁾ [kN]	5.4	9.4	7.8	10.4	12.9	18.0
$s_{cr,N}$	Critical spacing: [mm]	3.0 x h_{ef}					
$c_{cr,N}$	Critical edge distance: [mm]	1.5 x h_{ef}					
$s_{cr,sp}$	Critical spacing (splitting): [mm]	3.0 x h_{ef}					
$c_{cr,sp}$	Critical edge distance (splitting): [mm]	1.5 x h_{ef}					

- ¹⁾ In absence of other national regulations
²⁾ Pull-out failure is not decisive ($N_{Rk,c}^0 < N_{Rk,p}$)
³⁾ Equation 7.2 from EN 1992-4:2018

ARVEX SS concrete screw

Performances

Characteristic values for tension loads

Annex C3



English translation prepared by IETcc

Table C3: Displacements under tension loads for SS Carbon Steel

Characteristic values of displacements under tension loads of design method A				Performance						
				7.5		10.5		12.5		
h_{nom}	Overall anchor embedment depth in the concrete:	[mm]		40	55	50	60	60	70	85
Displacements under tension loads in uncracked concrete										
N	Service tension load in uncracked concrete C20/25 to C50/60:	[kN]		2.4	3.6	4.4	4.8	5.7	9.5	12.3
$\bar{\delta}_{N0}$	Short term displacement under tension loads:	[mm]		0.06	0.40	0.08	0.40	0.09	0.40	0.12
$\bar{\delta}_{N\infty}$	Long term displacement under tension loads:	[mm]		0.30	1.00	0.35	1.10	0.40	1.40	0.55
Displacements under tension loads in cracked concrete										
N	Service tension load in cracked concrete C20/25 to C50/60:	[kN]		1.2	2.4	2.5	3.6	4.0	5.7	8.6
$\bar{\delta}_{N0}$	Short term displacement under tension loads:	[mm]		0.10	0.60	0.12	0.70	0.15	0.50	0.17
$\bar{\delta}_{N\infty}$	Long term displacement under tension loads:	[mm]		1.10	1.40	1.20	1.20	1.25	1.40	0.55

Characteristic values of displacements under tension loads of design method A				Performance			
				14.2		16.5	
h_{nom}	Overall anchor embedment depth in the concrete:	[mm]		75	105	75	110
Displacements under tension loads in uncracked concrete							
N	Service tension load in uncracked concrete C20/25 to C50/60:	[kN]		11.3	18.1	8.2	19.0
$\bar{\delta}_{N0}$	Short term displacement under tension loads:	[mm]		0.08	0.10	0.10	0.90
$\bar{\delta}_{N\infty}$	Long term displacement under tension loads:	[mm]		0.40	0.40	0.45	1.40
Displacements under tension loads in cracked concrete							
N	Service tension load in cracked concrete C20/25 to C50/60:	[kN]		7.7	13.3	5.7	11.9
$\bar{\delta}_{N0}$	Short term displacement under tension loads:	[mm]		0.13	0.15	0.20	0.60
$\bar{\delta}_{N\infty}$	Long term displacement under tension loads:	[mm]		1.25	1.35	1.32	1.20

Table C4: Displacements under tension loads for SS Bimetal

Characteristic values of displacements under tension loads of design method A				Performance					
				7.5		10.5		12.5	
h_{nom}	Overall anchor embedment depth in the concrete:	[mm]		40	55	50	60	70	85
Displacements under tension loads in uncracked concrete									
N	Service tension load in uncracked concrete C20/25 to C50/60:	[kN]		2.95	5.47	4.44	7.06	8.76	13.42
$\bar{\delta}_{N0}$	Short term displacement under tension loads:	[mm]		0.11	0.15	0.23	0.32	0.39	0.54
$\bar{\delta}_{N\infty}$	Long term displacement under tension loads:	[mm]		0.40	0.50	0.55	0.55	0.60	0.65
Displacements under tension loads in cracked concrete									
N	Service tension load in cracked concrete C20/25 to C50/60:	[kN]		1.0	4.66	3.09	5.08	7.02	10.25
$\bar{\delta}_{N0}$	Short term displacement under tension loads:	[mm]		0.18	0.25	0.43	0.54	0.64	0.72
$\bar{\delta}_{N\infty}$	Long term displacement under tension loads:	[mm]		1.13	1.20	1.33	1.40	1.47	1.47

ARVEX SS concrete screw

Performances

Displacement under tension loads

Annex C4



Table C5: Characteristic values to shear loads for SS Carbon Steel

Characteristic values of resistance to shear loads				Performance					
				7.5		10.5		12.5	
h_{nom}	Overall anchor embedment depth in the concrete:	[mm]	40	55	50	60	60	70	85
Shear loads: steel failure without lever arm									
$V_{Rk,s}$	Shear steel characteristic resistance:	[kN]	9.3	7.5	16.3		25.6		
k_7	k_7 factor: ¹⁾	[-]	0.8		0.8		0.8		
γ_{Ms}	Partial safety factor: ²⁾	[-]	1.25		1.25		1.25		
Shear loads: steel failure with lever arm									
$M^0_{Rk,s}$	Characteristic bending moment:	[Nm]	15.2		35.3		69.3		
γ_{Ms}	Partial safety factor: ²⁾	[-]	1.25		1.25		1.25		
Shear loads: concrete pryout failure									
k_8	k_8 factor:	[-]	1.0	1.0	1.2	1.0	1.0	1.0	2.0
γ_{inst}	Installation safety factor: ²⁾	[-]	1.0		1.0		1.0		
Shear loads: concrete edge failure									
l_f	Effective anchorage depth under shear loads:	[mm]	29	42	37	45	44	52	65
d_{nom}	Nominal outer diameter of screw:	[mm]	6	6	8	8	10	10	10
γ_{inst}	Installation safety factor: ²⁾	[-]	1.0		1.0		1.0		

¹⁾ The diameter of the clearance hole does not meet the values given in EN 1992-4 Table 6.1. However, the group resistance under shear loading has been verified in the assessment through testing and accounted for in the factor k_7 .

²⁾ In absence of other national regulations.

Characteristic values of resistance to shear loads				Performance			
				14.2		16.5	
h_{nom}	Overall anchor embedment depth in the concrete:	[mm]	75	105	75	110	
Shear loads: steel failure without lever arm							
$V_{Rk,s}$	Shear steel characteristic resistance:	[kN]	40.3		57.9		
k_7	k_7 factor: ¹⁾	[-]	0.8		0.8		
γ_{Ms}	Partial safety factor: ²⁾	[-]	1.25		1.25		
Shear loads: steel failure with lever arm							
$M^0_{Rk,s}$	Characteristic bending moment:	[Nm]	137.1		235.9		
γ_{Ms}	Partial safety factor: ²⁾	[-]	1.25		1.25		
Shear loads: concrete pryout failure							
k_8	k_8 factor:	[-]	1.5	2.0	1.6	2.0	
γ_{inst}	Installation safety factor: ²⁾	[-]	1.0		1.0		
Shear loads: concrete edge failure							
l_f	Effective anchorage depth under shear loads:	[mm]	57	82	56	86	
d_{nom}	Nominal outer diameter of screw:	[mm]	12	12	14	14	
γ_{inst}	Installation safety factor: ²⁾	[-]	1.0		1.0		

¹⁾ The diameter of the clearance hole does not meet the values given in EN 1992-4 Table 6.1. However, the group resistance under shear loading has been verified in the assessment through testing and accounted for in the factor k_7 .

²⁾ In absence of other national regulations.

ARVEX SS concrete screw

Performances

Characteristic values for shear loads

Annex C5



Table C6: Characteristic values to shear loads for SS Bimetal

Characteristic values of resistance to shear loads		Performance					
		7.5		10.5		12.5	
h_{nom}	Overall anchor embedment depth in the concrete: [mm]	40	55	50	60	70	85
Shear loads: steel failure without lever arm							
$V_{Rk,s}$	Shear steel characteristic resistance: [kN]	8.5		16.7		27.2	
k_7	k_7 factor: ¹⁾ [-]	0.8	0.8	1.0		1.0	
γ_{Ms}	Partial safety factor: ²⁾ [-]	1.25		1.25		1.25	
Shear loads: steel failure with lever arm							
$M^0_{Rk,s}$	Characteristic bending moment: [Nm]	13.2	13.2	36.6		75.7	
γ_{Ms}	Partial safety factor: ²⁾ [-]	1.25		1.25		1.25	
Shear loads: concrete pryout failure							
k_8	k_8 factor: [-]	1.0	1.0	1.0	1.0	1.09	2.0
γ_{inst}	Installation safety factor: ²⁾ [-]	1.0		1.0		1.0	
Shear loads: concrete edge failure							
l_f	Effective anchorage depth under shear loads: [mm]	29	42	37	45	52	65
d_{nom}	Nominal outer diameter of screw: [mm]	6	6	8	8	10	10
γ_{inst}	Installation safety factor: ²⁾ [-]	1.0		1.0		1.0	

¹⁾ The diameter of the clearance hole does not meet the values given in EN 1992-4 Table 6.1. However, the group resistance under shear loading has been verified in the assessment through testing and accounted for in the factor k_7 .

²⁾ In absence of other national regulations.

ARVEX SS concrete screw

Performances

Characteristic values for shear loads

Annex C6



Table C7: Displacements under shear loads for SS Carbon Steel

Characteristic values of displacements under shear loads of design method A			Performances						
			7.5		10.5		12.5		
h_{nom}	Overall anchor embedment depth in the concrete:	[mm]	40	55	50	60	60	70	85
Displacements under shear loads in uncracked concrete									
V	Service shear load in uncracked concrete C20/25 to C50/60:	[kN]	3.0	3.6	4.4	4.8	5.7	9.5	12.3
$\bar{\delta}_{V0}$	Short term displacement under shear loads:	[mm]	0.47	0.4	0.50	0.40	0.40	0.40	0.80
$\bar{\delta}_{V\infty}$	Long term displacement under shear loads:	[mm]	0.70	1.0	0.75	1.10	0.60	1.40	1.20
Displacements under shear loads in cracked concrete									
V	Service shear load in cracked concrete C20/25 to C50/60:	[kN]	2.1	2.4	3.1	3.6	4.0	5.7	8.6
$\bar{\delta}_{V0}$	Short term displacement under shear loads:	[mm]	0.40	0.60	0.45	0.70	0.50	0.50	0.6
$\bar{\delta}_{V\infty}$	Long term displacement under shear loads:	[mm]	0.60	1.40	0.67	1.20	0.75	1.40	0.90

Characteristic values of displacements under shear loads of design method A			Performances			
			14.2		16.5	
h_{nom}	Overall anchor embedment depth in the concrete:	[mm]	75	105	75	110
Displacements under shear loads in uncracked concrete						
V	Service shear load in uncracked concrete C20/25 to C50/60:	[kN]	8.4	17.4	8.2	19.0
$\bar{\delta}_{V0}$	Short term displacement under shear loads:	[mm]	1.00	1.10	0.55	0.90
$\bar{\delta}_{V\infty}$	Long term displacement under shear loads:	[mm]	1.50	1.80	0.82	1.4
Displacements under shear loads in cracked concrete						
V	Service shear load in cracked concrete C20/25 to C50/60:	[kN]	5.9	12.2	5.7	11.9
$\bar{\delta}_{V0}$	Short term displacement under shear loads:	[mm]	0.85	1.00	0.50	0.60
$\bar{\delta}_{V\infty}$	Long term displacement under shear loads:	[mm]	1.20	1.50	0.75	1.20

¹⁾ No Performance Determined (NPD)

Table C8: Displacements under shear loads for SS Bimetal

Characteristic values of displacements under shear loads of design method A			Performances					
			7.5		10.5		12.5	
h_{nom}	Overall anchor embedment depth in the concrete:	[mm]	40	55	50	60	70	85
Displacements under shear loads in uncracked concrete								
V	Service shear load in uncracked concrete C20/25 to C50/60:	[kN]	2.7	3.3	4.0	5.3	8.0	11.2
$\bar{\delta}_{V0}$	Short term displacement under shear loads:	[mm]	1.42	1.55	1.64	1.75	1.78	2.11
$\bar{\delta}_{V\infty}$	Long term displacement under shear loads:	[mm]	2.13	2.33	2.46	2.63	2.67	3.17
Displacements under shear loads in cracked concrete								
V	Service shear load in cracked concrete C20/25 to C50/60:	[kN]	1.9	2.3	2.8	3.7	5.6	7.8
$\bar{\delta}_{V0}$	Short term displacement under shear loads:	[mm]	1.22	1.34	1.45	1.52	1.57	1.67
$\bar{\delta}_{V\infty}$	Long term displacement under shear loads:	[mm]	1.83	2.01	2.18	2.28	2.36	2.51

ARVEX SS concrete screw

Performances

Displacements under shear loads

Annex C7



Table C9: Essential characteristics for seismic performance category C1 for SS Carbon Steel

Essential characteristics for seismic performance category C1			Performances					
			7.5	10.5	12.5	14.2	16.5	
h_{nom}	Overall anchor embedment depth in the concrete:	[mm]	40	55	60	85	105	110
Steel failure for tension and shear loads								
$N_{Rk,s,C1}$	Characteristic resistance:	[kN]	18.7	32.7	51.2	80.6	115.9	
γ_{Ms}	Partial safety factor ¹⁾ :	[-]	1.5	1.5	1.5	1.5	1.5	1.5
$V_{Rk,s,C1}$	Characteristic resistance:	[kN]	6.4	7.5	16.3	24.3	39.9	57.9
γ_{Ms}	Partial safety factor ¹⁾ :	[-]	1.25	1.25	1.25	1.25	1.25	1.25
Pull out failure								
$N_{Rk,p,C1}$	Characteristic resistance in cracked concrete:	[kN]	2.9	5.6	9.0	24.0	24.3	30.0
γ_{inst}	Robustness:	[-]	1.2	1.2	1.2	1.0	1.0	1.0
Concrete cone failure								
h_{ef}	Effective embedment depth:	[mm]	29	42	45	65	82	86
$s_{cr,N}$	Concrete Spacing:	[mm]	87	126	135	195	246	258
$c_{cr,N}$	cone failure Edge distance:	[mm]	43	63	67	98	123	129
γ_{inst}	Installation safety factor:	[-]	1.2	1.2	1.2	1.0	1.0	1.0
Concrete pry-out failure								
k_s	Pry-out factor:	[-]	1.0	1.0	1.0	2.0	2.0	2.0
γ_{inst}	Installation safety factor:	[-]	1.0	1.0	1.0	1.0	1.0	1.0
Concrete edge failure								
$l_t = h_{ef}$	Effective length of fastener under shear loads:	[mm]	29	42	45	65	82	86
d_{nom}	Nominal outer diameter of screw:	[mm]	6	6	8	10	12	14
γ_{inst}	Installation safety factor:	[-]	1.0	1.0	1.0	1.0	1.0	1.0

¹⁾ In absence of other national regulations

ARVEX SS concrete screw

Performances

Essential characteristics for seismic performance category C1

Annex C8



Table C10: Essential characteristics for seismic performance category C2 for SS Carbon Steel

Essential characteristics for seismic performance category C2			Performances			
			10.5	12.5	14.2	16.5
h_{nom}	Overall anchor embedment depth in the concrete:	[mm]	60	85	105	110
Steel failure for tension and shear loads						
$N_{Rk,s,C2}$	Characteristic resistance:	[kN]	32.7	51.2	80.6	115.9
γ_{Ms}	Partial safety factor ¹⁾ :	[-]	1.5	1.5	1.5	1.5
$V_{Rk,s,C2}$	Characteristic resistance:	[kN]	13.7	16.1	28.3	41.1
γ_{Ms}	Partial safety factor ¹⁾ :	[-]	1.25	1.25	1.25	1.25
Pull out failure						
$N_{Rk,p,C2}$	Characteristic resistance in cracked concrete:	[kN]	5.2	11.0	3.2	9.6
γ_{inst}	Robustness:	[-]	1.2	1.0	1.0	1.0
Concrete cone failure						
h_{ef}	Effective embedment depth:	[mm]	45	65	82	86
$s_{cr,N}$	Concrete Spacing:	[mm]	135	195	246	258
$c_{cr,N}$	cone failure Edge distance:	[mm]	68	98	123	129
γ_{inst}	Installation safety factor:	[-]	1.2	1.0	1.0	1.0
Concrete pry-out failure						
k_s	Pry-out factor:	[-]	1.0	2.0	2.0	2.0
γ_{inst}	Installation safety factor:	[-]	1.0	1.0	1.0	1.0
Concrete edge failure						
$l_f = h_{ef}$	Effective length of fastener under shear loads:	[mm]	45	65	82	86
d_{nom}	Nominal outer diameter of screw:	[mm]	8.0	10.0	12.0	14.0
γ_{inst}	Installation safety factor:	[-]	1.0	1.0	1.0	1.0
Displacements						
$\bar{\delta}_{N,C2} (DLS)$	Displacement at	[mm]	0.15	0.35	0.65	0.73
$\bar{\delta}_{V,C2} (DLS)$	Damage Limitation State: ²⁾	[mm]	4.15	5.16	5.65	5.67
$\bar{\delta}_{N,C2} (ULS)$	Displacement at	[mm]	1.41	1.11	4.66	2.06
$\bar{\delta}_{V,C2} (ULS)$	Ultimate Limitation State: ²⁾	[mm]	8.27	7.90	12.14	7.90

DLS: Damage Limitation State: see EN 1992-4, 2.2.1)
ULS: Ultimate Limitation State: see EN 1992-4 2.2.1)

- ¹⁾ In absence of other national regulations.
²⁾ The listed displacements represent mean values.

ARVEX SS concrete screw

Performances

Essential characteristics for seismic performance category C2

Annex C9



Table D1: Characteristic values to fire resistance for SS Carbon Steel

Fire resistance duration = 30 minutes			Performances										
			7.5		10.5		12.5			14.2		16.5	
h_{nom}	Overall anchor embedment depth in the concrete:	[mm]	40	55	50	60	60	70	85	75	105	75	110
Tension loads, steel failure													
$N_{Rk,s,fi,30}$	Characteristic resistance:	[kN]	0.23	0.23	0.41	0.41	0.95	0.95	0.95	2.02	2.02	2.91	2.91
Pull-out failure													
$N_{Rk,p,fi,30}$	Character. resistance in concrete:	[kN]	0.77	1.43	1.58	2.28	3.66	3.60	6.09	4.85	8.38	5.04	7.43
Concrete cone failure ¹⁾													
$N_{Rk,c,fi,30}$	Character. resistance in concrete:	[kN]	0.78	1.97	1.43	2.34	2.21	3.36	5.86	4.22	10.48	4.04	11.81
Shear loads steel failure without lever arm													
$V_{Rk,s,fi,30}$	Characteristic resistance	[kN]	0.23	0.23	0.41	0.41	0.95	0.95	0.95	2.02	2.02	2.91	2.91
Shear loads, steel failure with lever arm													
$M_{Rk,s,fi,30}$	Characteristic bending resistance:	[Nm]	0.19	0.19	0.44	0.44	1.29	1.29	1.29	3.43	3.43	5.93	5.93

Fire resistance duration = 60 minutes			Performances										
			7.5		10.5		12.5			14.2		16.5	
h_{nom}	Overall anchor embedment depth in the concrete:	[mm]	40	55	50	60	60	70	85	75	105	75	110
Tension loads, steel failure													
$N_{Rk,s,fi,60}$	Characteristic resistance:	[kN]	0.21	0.21	0.37	0.37	0.83	0.83	0.83	1.51	1.51	2.18	2.18
Pull-out failure													
$N_{Rk,p,fi,60}$	Character. resistance in concrete:	[kN]	0.77	1.43	1.58	2.28	3.66	3.60	6.09	4.85	8.38	5.04	7.43
Concrete cone failure ¹⁾													
$N_{Rk,c,fi,60}$	Character. resistance in concrete:	[kN]	0.78	1.97	1.43	2.34	2.21	3.36	5.86	4.22	10.48	4.04	11.81
Shear loads steel failure without lever arm													
$V_{Rk,s,fi,60}$	Characteristic resistance:	[kN]	0.21	0.21	0.37	0.37	0.83	0.83	0.83	1.51	1.51	2.18	2.18
Shear loads, steel failure with lever arm													
$M_{Rk,s,fi,60}$	Characteristic bending resistance:	[Nm]	0.17	0.17	0.40	0.40	1.12	1.12	1.12	2.57	2.57	4.45	4.45

¹⁾ As a rule, splitting failure can be neglected when cracked concrete and reinforcement is assumed.

Note: In absence of other national regulations, the partial safety factor for resistance under fire exposure $\gamma_{M,fi} = 1.0$ is recommended for steel failure and concrete related failure modes under shear loading. In case of concrete related failure modes under tension $\gamma_{M,fi} = \gamma_{inst.}$.

ARVEX SS concrete screw

Performances
Characteristic values for fire resistance

Annex D1



Table D1: Characteristic values to fire resistance for SS Carbon Steel (continuation)

Fire resistance duration = 90 minutes			Performances										
			7.5		10.5		12.5			14.2		16.5	
h_{nom}	Overall anchor embedment depth in the concrete:	[mm]	40	55	50	60	60	70	85	75	105	75	110
Tension loads, steel failure													
$N_{Rk,s,fi,90}$	Characteristic resistance:	[kN]	0.16	0.16	0.29	0.29	0.64	0.64	0.64	1.31	1.31	1.89	1.89
Pull-out failure													
$N_{Rk,p,fi,90}$	Character. resistance in concrete:	[kN]	0.77	1.43	1.58	2.28	3.66	3.60	6.09	4.85	8.38	5.04	7.43
Concrete cone failure ¹⁾													
$N_{Rk,c,fi,90}$	Character. resistance in concrete:	[kN]	0.78	1.97	1.43	2.34	2.21	3.36	5.86	4.22	10.48	4.04	11.81
Shear loads steel failure without lever arm													
$V_{Rk,s,fi,90}$	Characteristic resistance:	[kN]	0.16	0.16	0.29	0.29	0.64	0.64	0.64	1.31	1.31	1.89	1.89
Shear loads, steel failure with lever arm													
$M_{Rk,s,fi,90}$	Characteristic bending resistance:	[Nm]	0.13	0.13	0.31	0.31	0.86	0.86	0.86	2.23	2.23	3.85	3.85

Fire resistance duration = 120 minutes			Performances										
			7.5		10.5		12.5			14.2		16.5	
h_{nom}	Overall anchor embedment depth in the concrete:	[mm]	40	55	50	60	60	70	85	75	105	75	110
Tension loads, steel failure													
$N_{Rk,s,fi,120}$	Characteristic resistance:	[kN]	0.11	0.11	0.20	0.20	0.51	0.51	0.51	1.01	1.01	1.45	1.45
Pull-out failure													
$N_{Rk,p,fi,120}$	Character. resistance in concrete:	[kN]	0.62	1.14	1.27	1.82	2.93	2.88	4.87	3.88	6.70	4.03	5.94
Concrete cone failure ¹⁾													
$N_{Rk,c,fi,120}$	Character. resistance in concrete:	[kN]	0.62	1.57	1.15	1.87	1.77	2.69	4.69	3.38	8.39	3.23	9.45
Shear loads steel failure without lever arm													
$V_{Rk,s,fi,120}$	Characteristic resistance:	[kN]	0.11	0.11	0.20	0.20	0.51	0.51	0.51	1.01	1.01	1.45	1.45
Shear loads, steel failure with lever arm													
$M_{Rk,s,fi,120}$	Characteristic bending resistance:	[Nm]	0.09	0.09	0.22	0.22	0.69	0.69	0.69	1.71	1.71	2.96	2.96

¹⁾ As a rule, splitting failure can be neglected when cracked concrete and reinforcement is assumed.

Note: In absence of other national regulations, the partial safety factor for resistance under fire exposure $\gamma_{M,fi} = 1.0$ is recommended for steel failure and concrete related failure modes under shear loading. In case of concrete related failure modes under tension $\gamma_{M,fi} = \gamma_{inst}$.

ARVEX SS concrete screw

Performances
Characteristic values for fire resistance

Annex D2



Table D2: Spacing and edge distances for SS Carbon Steel

Space and edge distances			Performances										
			7.5		10.5		12.5		14.2		16.5		
h_{nom}	Overall anchor embedment depth in the concrete:	[mm]	40	55	50	60	60	70	85	75	105	75	110
h_{ef}	Effective anchorage depth:	[mm]	29	42	37	45	44	52	65	57	82	56	86
$S_{cr,N}$	Spacing	[mm]	116	168	148	180	176	208	260	228	328	224	344
S_{min}	Minimum spacing	[mm]	35	45	35	50	50	60	70	70	70	75	100
$C_{cr,N}$	Edge distance	[mm]	58	84	74	90	88	104	130	114	164	112	172
C_{min}	Minimum edge distance (one side fire)	[mm]	35	45	35	50	40	60	60	45	45	45	100
C_{min}	Minimum edge distance (two sides fire)	[mm]	300	300	300	300	300	300	300	300	300	300	300
γ_{Msp}	Partial safety factor ^{*)}	[-]	1.0	1.0	1.0	1.0	1.0	1.0	1.0	1.0	1.0	1.0	1.0

*) In absence of other national regulations

Concrete pry-out failure

k_8 factor values for SS made of Carbon Steel in Table C5
According EN 1992-4:2018, these values of k_8 factor and the relevant values of $N_{Rk,c,fi}$ given in the above tables have to be considered in design.

Concrete edge failure

The characteristic resistance $V^0_{Rk,c,fi}$ in C20/25 to C50/60 concrete is determined by:
 $V^0_{Rk,c,fi} = 0.25 \times V^0_{Rk,c}$ ($\leq R90$) and $V^0_{Rk,c,fi} = 0.20 \times V^0_{Rk,c}$ (R120)
 With $V^0_{Rk,c}$ initial value of the characteristic resistance in cracked concrete C20/25 under normal temperature according to EN 1992-4:2018.

ARVEX SS concrete screw

Performances
Characteristic values for fire resistance

Annex D3



Table D3: Characteristic values to fire resistance for SS Bimetal

Fire resistance duration = 30 minutes			Performances					
			7.5		10.5		12.5	
h_{nom}	Overall anchor embedment depth in the concrete:	[mm]	40	55	50	60	70	85
Tension loads, steel failure								
$N_{Rk,s,fi,30}$	Characteristic resistance	[kN]	0.21		0.84		1.70	
Pull-out failure								
$N_{Rk,p,fi,30}$	Character. resistance in concrete C20/25 to C50/60	[kN]	0.53	2.94	1.95	3.20	4.42	6.46
Concrete cone failure¹⁾								
$N_{Rk,c,fi,30}$	Character. resistance in concrete C20/25 to C50/60	[kN]	0.78	1.97	1.43	2.34	3.36	5.86
Shear loads steel failure without lever arm								
$V_{Rk,s,fi,30}$	Characteristic resistance	[kN]	0.21		0.84		1.70	
Shear loads, steel failure with lever arm								
$M_{Rk,s,fi,30}$	Characteristic bending resistance	[Nm]	0.17		0.92		2.37	

Fire resistance duration = 60 minutes			Performances					
			7.5		10.5		12.5	
h_{nom}	Overall anchor embedment depth in the concrete:	[mm]	40	55	50	60	70	85
Tension loads, steel failure								
$N_{Rk,s,fi,60}$	Characteristic resistance	[kN]	0.19		0.67		1.36	
Pull-out failure								
$N_{Rk,p,fi,60}$	Character. resistance in concrete C20/25 to C50/60	[kN]	0.53	2.94	1.95	3.20	4.42	6.46
Concrete cone failure¹⁾								
$N_{Rk,c,fi,60}$	Character. resistance in concrete C20/25 to C50/60	[kN]	0.78	1.97	1.43	2.34	3.36	5.86
Shear loads steel failure without lever arm								
$V_{Rk,s,fi,60}$	Characteristic resistance	[kN]	0.19		0.67		1.36	
Shear loads, steel failure with lever arm								
$M_{Rk,s,fi,60}$	Characteristic bending resistance	[Nm]	0.15		0.73		1.90	

Fire resistance duration = 90 minutes			Performances					
			7.5		10.5		12.5	
h_{nom}	Overall anchor embedment depth in the concrete:	[mm]	40	55	50	60	70	85
Tension loads, steel failure								
$N_{Rk,s,fi,90}$	Characteristic resistance	[kN]	0.15		0.50		1.09	
Pull-out failure								
$N_{Rk,p,fi,90}$	Character. resistance in concrete C20/25 to C50/60	[kN]	0.53	2.94	1.95	3.20	4.42	6.46
Concrete cone failure¹⁾								
$N_{Rk,c,fi,90}$	Character. resistance in concrete C20/25 to C50/60	[kN]	0.78	1.97	1.43	2.34	3.36	5.86
Shear loads steel failure without lever arm								
$V_{Rk,s,fi,90}$	Characteristic resistance	[kN]	0.15		0.50		1.09	
Shear loads, steel failure with lever arm								
$M_{Rk,s,fi,90}$	Characteristic bending resistance	[Nm]	0.12		0.55		1.52	

¹⁾ As a rule, splitting failure can be neglected when cracked concrete and reinforcement is assumed.

Note: In absence of other national regulations, the partial safety factor for resistance under fire exposure $\gamma_{M,fi} = 1.0$ is recommended for steel failure and concrete related failure modes under shear loading. In case of concrete related failure modes under tension $\gamma_{M,fi} = \gamma_{inst.}$

ARVEX SS concrete screw

Performances

Characteristic values for fire resistance

Annex D4



Table D3: Characteristic values to fire resistance for SS Bimetal (continuation)

Fire resistance duration = 120 minutes			Performances					
			7.5		10.5		12.5	
h_{nom}	Overall anchor embedment depth in the concrete:	[mm]	40	55	50	60	70	85
Tension loads, steel failure								
$N_{Rk,s,fi,120}$	Characteristic resistance	[kN]	0.11		0.42		0.95	
Pull-out failure								
$N_{Rk,p,fi,120}$	Character. resistance in concrete C20/25 to C50/60	[kN]	0.42	2.35	1.56	2.56	3.54	5.17
Concrete cone failure¹⁾								
$N_{Rk,c,fi,120}$	Character. resistance in concrete C20/25 to C50/60	[kN]	0.62	1.57	1.15	1.87	2.69	4.69
Shear loads steel failure without lever arm								
$V_{Rk,s,fi,120}$	Characteristic resistance	[kN]	0.11		0.42		0.95	
Shear loads, steel failure with lever arm								
$M_{Rk,s,fi,120}$	Characteristic bending resistance	[Nm]	0.08		0.46		1.33	

¹⁾ As a rule, splitting failure can be neglected when cracked concrete and reinforcement is assumed.

Note: In absence of other national regulations, the partial safety factor for resistance under fire exposure $\gamma_{M,fi} = 1.0$ is recommended for steel failure and concrete related failure modes under shear loading. In case of concrete related failure modes under tension $\gamma_{M,fi} = \gamma_{inst.}$

Table D4: Spacing and edge distances for SS Bimetal

Spacing and edge distances			Performances					
			7.5		10.5		12.5	
h_{nom}	Overall anchor embedment depth in the concrete:	[mm]	40	55	50	60	70	85
h_{ef}	Effective anchorage depth:	[mm]	29	42	37	45	52	65
$S_{cr,N}$	Spacing	[mm]	116	168	148	180	208	260
S_{min}	Minimum spacing	[mm]	35	35	35	50	60	70
$C_{cr,N}$	Edge distance	[mm]	58	84	74	90	105	130
C_{min}	Minimum edge distance (one side fire)	[mm]	35	35	35	50	60	70
C_{min}	Minimum edge distance (two sides fire)	[mm]	300	300	300	300	300	300
γ_{Msp}	Partial safety factor ¹⁾	[-]	1.0	1.0	1.0	1.0	1.0	1.0

¹⁾ In absence of other national regulations

Concrete pry-out failure

k_8 factor values for SS made of Bimetal Steel in Table C6
According EN 1992-4:2018, these values of k_8 factor and the relevant values of $N_{Rk,c,fi}$ given in the above tables have to be considered in design.

Concrete edge failure

The characteristic resistance $V^0_{Rk,c,fi}$ in C20/25 to C50/60 concrete is determined by:
 $V^0_{Rk,c,fi} = 0.25 \times V^0_{Rk,c}$ ($\leq R90$) and $V^0_{Rk,c,fi} = 0.20 \times V^0_{Rk,c}$ (R120)
With $V^0_{Rk,c}$ initial value of the characteristic resistance in cracked concrete C20/25 under normal temperature according to EN 1992-4:2018.

ARVEX SS concrete screw

Performances

Characteristic values for fire resistance

Annex D5

